

# TA-Smart-Dp



## Smart valves

2-way Smart electronic differential pressure controller with flow, temperature and power measurement capabilities

# TA-Smart-Dp

The ultrasonic flow measurement technology combined with unique actuation algorithms capabilities provide best-in-class control performances. TA-Smart-Dp is designed to keep a stable differential pressure over the load. This enables accurate and stable conditions to provide superior control valve authority for modulating control valves, additionally it can limit noise and simplify the balancing procedure. Its compact arrangement and simple set-up reduces installation and commissioning time.



## Key features

- > **Precise and stable differential pressure control**  
Delivers desired differential pressure ensuring accurate balancing.
- > **Optional cloud connection**  
Easy remote access to data and configuration parameters allows to verify and adjust system performance.
- > **High measurement accuracy**  
High flow and temperature measurement accuracies in all configurations (medium type, and temperature) for all flow regimes.
- > **Compactness and limited number of components**  
Reduces installation time and space requirements facilitating retrofit installation.
- > **Convenient, reliable setup**  
Fully customizable and commissionable using Bluetooth enabled smart device reducing commissioning and diagnostic time.
- > **Easy diagnostics**  
Continuous measurement (flow, temperature, power...) enables accurate error identification in system hydraulics.
- > **Versatility in communication**  
Digital (key Bus protocols and MQTT) and Analog (0(2)-10 VDC or 0(4)-20 mA).

## Technical description

### Application:

Heating and cooling systems.

### Functions:

Differential pressure control  
Pre-setting  $\Delta p$  over the load ( $\Delta p_L$ )  
Measuring ( $\Delta p_L$ )  
Reading (flow, power, energy, supply/return temperature,  $\Delta T$ , position)  
Manual override (via HyTune app)  
Mode, status and position indication  
Valve blockage protection  
Valve clogging detection  
Error safe position  
Diagnostic  
Logging  
Delayed start-up

### Dimensions:

DN 20-125

### Pressure class:

DN 20-50: PN 25  
DN 65-125: PN 16, PN 25

### Differential pressure ( $\Delta p_V$ ):

Max. differential pressure ( $\Delta p_{V_{max}}$ ):  
400 kPa = 4 bar  
Closing pressure: 600 kPa = 6 bar  
 $\Delta p_{V_{max}}$  = The maximum allowed pressure drop over the valve to fulfill all stated performances.

### Setting range, differential pressure

**Dp sensor:**  
10-100 kPa  
40-400 kPa  
Max. differential pressure ( $\Delta p_{burst}$ ):  
500 kPa = 5 bar  
1200 kPa = 12 bar  
 $\Delta p_{burst}$  = Maximum differential pressure that may be applied to the sensor.

### Flow range:

The flow ranges ( $q_{setmin} - q_{nom}$ ) for different dimensions:

DN 20: 380 - 1900 l/h  
DN 25: 540 - 2700 l/h  
DN 32: 920 - 4600 l/h  
DN 40: 1560 - 7800 l/h  
DN 50: 2680 - 13400 l/h  
DN 65: 5800 - 29000 l/h  
DN 80: 8640 - 43200 l/h  
DN 100: 14200 - 71000 l/h  
DN 125: 22400 - 112000 l/h  
Minimum controllable flows ( $q_{contr.min}$ ) 0.5% of  $q_{nom}$   
 $q_{setmin}$  = Minimum settable flow.  
 $q_{nom}$  = Maximum settable flow.

---

**Measurement accuracy:**

Flow:

Water: From 2% accuracy at 100% of  $q_{nom}$  to 2.4% accuracy at 5% of  $q_{nom}$  (according MID-Class 2 EN1434).

Water+glycol: From 3% accuracy at 100% of  $q_{nom}$  to 4% accuracy at 5% of  $q_{nom}$  (according to MID-Class 3 EN1434). (see "Flow accuracy")

Temperature difference:

±0.1 K @  $\Delta T = 6$  K (for cooling)  
 ±0.15 K @  $\Delta T = 10$  K (for heating)  
 ±0.2 K @  $\Delta T = 20$  K (for heating)

Dp sensor:

<2.5 kPa for 10-100 kPa sensor  
 <10 kPa for 40-400 kPa sensor

---

**Temperature:**

Max. working temperature: 110°C

Min. working temperature: -10°C

Operating environment: 0°C – +50°C  
 (5-95%RH, non-condensing)

Storage environment: -20°C – +70°C  
 (5-95%RH, non-condensing)

Dp sensor:

Max. working temperature: 80°C

Min. working temperature: -15°C

Operating environment: -15°C – +80°C  
 (5-95%RH, non-condensing)

Storage environment: -40°C – +80°C  
 (5-95%RH, non-condensing)

---

**Media:**

Water or neutral fluids, water-glycol mixtures (0-57%).

---

**Leakage rate:**

DN 20-50: Leakage rate <0.01% of  $q_{nom}$  with correct flow direction (Class IV according to EN 60534-4)

DN 65-125: Tight sealing with correct flow direction (Class V according to EN 60534-4)

---

**Supply voltage:**

24 VAC/VDC ±15%.

Frequency 50/60 Hz ±3 Hz.

Dp sensor:

18-33 VDC or 24 VAC +15/-10 % (0-10 V)

**NOTE:** 24 VAC/VDC power supply must be provided only with safety isolating transformer according to EN 61558-2-6.

---

**Power consumption:**

DN 20-50:

Operation: < 4.0 W (24 VDC);

< 5.6 VA (24 VAC)

Standby: < 1.9 W (24 VDC);

< 3.3 VA (24 VAC)

DN 65-80:

Operation: < 5.8 W (24 VDC);

< 10 VA (24 VAC)

Standby: < 1.9 W (24 VDC);

< 3.3 VA (24 VAC)

---

DN 100-125:

Operation: < 7.7 W (24 VDC);  
 < 10.8 VA (24 VAC)

Standby: < 1.9 W (24 VDC);  
 < 3.3 VA (24 VAC)

---

**Input signal:**

By BACnet/Modbus

---

**Output signal:**

BACnet/Modbus

0(2)-10 VDC, max. 8 mA, min. 1.25 kΩ.

Dp sensor: 0-10 V

---

**Wireless:**

Bluetooth Low Energy (BLE)

Thread

---

**Temperature sensor cable:**

DN 20-50: 3 m halogen free

DN 65-125: 5 m halogen free

10 m halogen free cable on request.

---

**Dp sensor cable:**

1.5 m, 3x0.25 mm<sup>2</sup>, PVC, PG7.

---

**Ingress protection:**

IP54

Dp sensor: IP65

(according to EN 60529)

---

**Protection class:**

(according to EN 61140)

III (SELV)

---

**Material:**

DN 20-50:

Valve body: AMETAL®

Valve insert: AMETAL®

Valve plug: AMETAL® and PTFE

Spindle: Stainless steel

Spindle seal: EPDM O-ring

Internal plastic parts: PPS

Springs: Stainless steel

O-rings: EPDM

Temperature housing: AMETAL®.

---

DN 65-125:

Valve body: Ductile iron EN-GJS-400-15

Valve insert: Ductile iron EN-GJS-400-15 and brass

Valve plug: Stainless steel and EPDM

O-ring

Valve seat: Stainless steel

Spindle: Stainless steel

Spindle seal: EPDM

Springs: Stainless steel

O-rings: EPDM

---

SmartBox (DN 20-125):

Cover: PC/ABS, red.

Housing: PC/ABS, TPE

---

Actuators:

DN 20-50:

Cover: PC/ABS GF8, white RAL 9016,  
 grey RAL 7047.

Housing: PA GF40.

Swivelling nut: Nickel-plated brass.

DN 65-125:

Cover: PBT, orange RAL 2011, grey  
 RAL 7043.

Bracket: Alu EN44200

---

Cables: Halogen free

Dp sensor:

Sensor housing: Stainless steel

X8CrNiS18-9 (No 1.4305 EN 10 088-3).

Membrane: Ceramic

Sealing: EPDM

---

AMETAL® is the dezincification resistant alloy of IMI Hydronic Engineering.

---

**Surface treatment:**

DN 20-50: Non treated

DN 65-125: Electrophoretic painting

---

**Marking:**

Valve body:

DN 20-50: IMI TA, PN, DN, inch size,  
 country of origin and flow direction arrow.

DN 65-125: IMI TA, DN, inch size,  
 material and flow direction arrow. Label  
 with technical specification, country of  
 origin and CE.

SmartBox: IMI TA

Actuator: IMI TA, model, technical spec.,  
 LED info.

Dp sensor: Label with technical  
 specification.

---

**Pipe connection:**

DN 20-50: External thread according to  
 ISO 228.

DN 65-125: Flanges according to  
 EN-1092-2, type 21. Face to face length  
 according to EN 558, series 1.

---

**Certification and directives:**

EMC-D. 2014/30/EU: EN 60730-1, -2-14.

Product standards EN 60730-x.

PED: 2014/68/EU

Dp sensor:

CE certification EN 61326-2-3.

---

## Flow accuracy

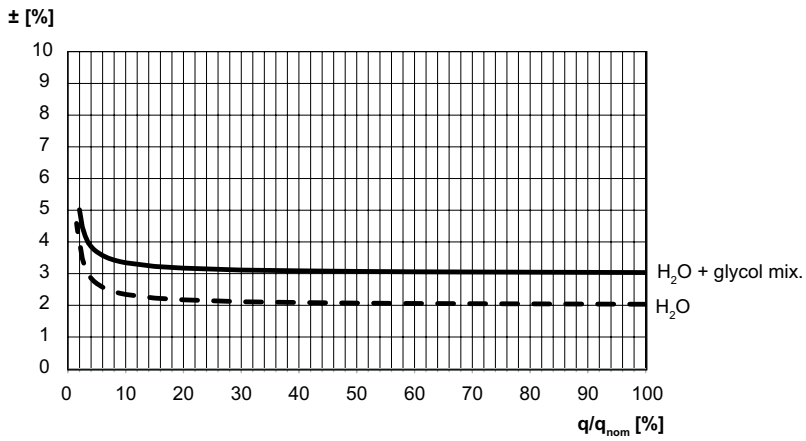

## Installation

DN 20-50

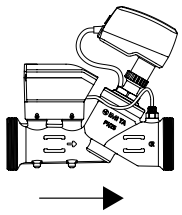

DN 65-125

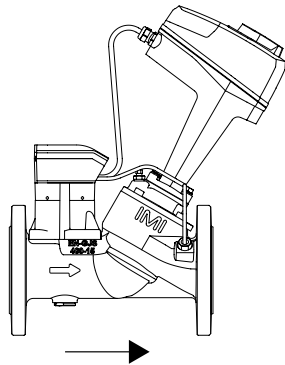

DN 20-50

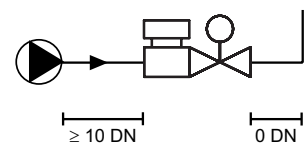
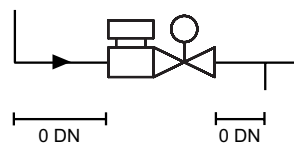

DN 65-125

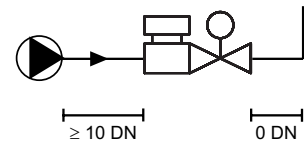
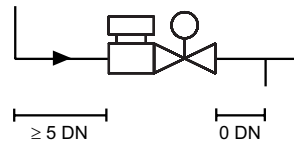

**Note:** Free space is required above the actuator/temperature sensor pocket for easy mounting/dismounting.

DN 20-50

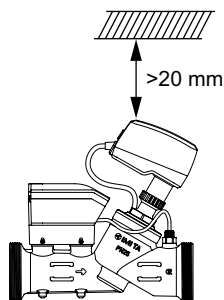

DN 65-125

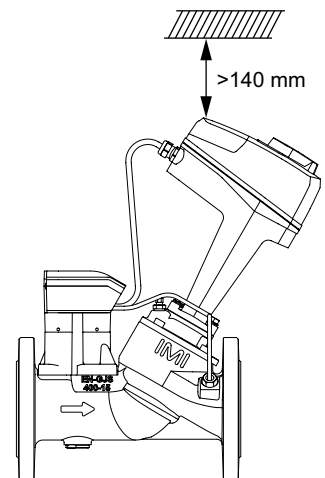

DN 20-50

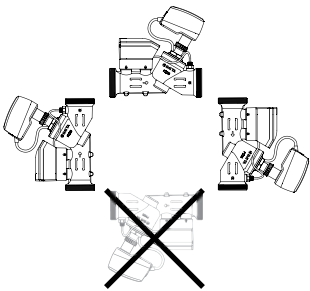

DN 65-125

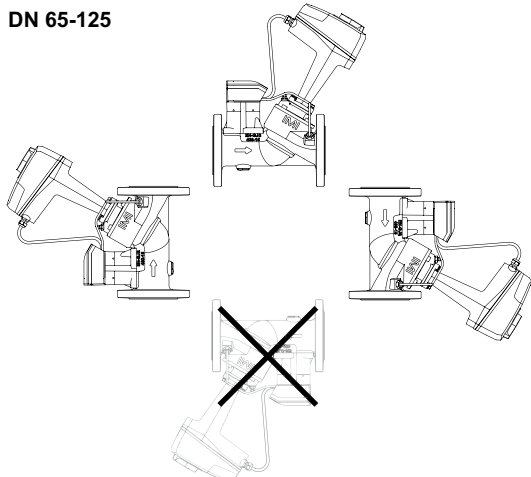

## Articles

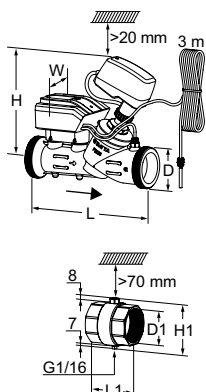

### TA-Smart-Dp DN 20-50

Including temperature housing and 3 m temperature sensor cable.  
External threads according to ISO 228.

DN	D	L	H	W	Kvs	Kg	EAN	Article No
20	G1	180	174	97	3,15	1,6	7318794178014	322232-00020
25	G1 1/4	187	174	97	4,35	1,8	7318794178021	322232-00025
32	G1 1/2	200	199	97	7,28	2,1	7318794178038	322232-00032
40	G2	218	198	97	12,3	3,0	7318794178045	322232-00040
50	G2 1/2	239	198	97	21,2	3,9	7318794178052	322232-00050

### Temperature housing incl. temperature sensor pocket and capillary pipe connection

Included in TA-Smart/-Dp DN 20-50.  
Internal threads according to ISO 228.

DN	D1	L1	H1
20*	G3/4	60	56
25	G1	62	61
32	G1 1/4	66	70
40	G1 1/2	67	76
50	G2	68	89

\*) Can be connected to smooth pipes by KOMBI compression coupling.

### TA-Smart-Dp DN 65-125

Including temperature sensor pocket and 5 m temperature sensor cable.  
Free space >70 mm is required above the temperature pocket.  
Flanges according to EN-1092-2, type 21.

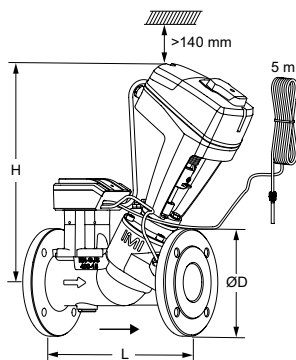

DN	Number of bolt holes	D	L	H	Kvs	Kg	EAN	Article No
<b>PN 16</b>								
65	4	185	290	377	50	17	7318794178069	322232-01265
80	8	200	310	380	70	19	7318794178076	322232-01280
100	8	220	350	438	120	29	7318794178083	322232-01290
125	8	250	400	444	190	35	7318794178090	322232-01291
<b>PN 25</b>								
65	8	185	290	377	50	17	7318794178106	322232-01365
80	8	200	310	380	70	19	7318794178113	322232-01380
100	8	235	350	438	120	29	7318794178120	322232-01390
125	8	270	400	444	190	35	7318794178137	322232-01391

→ = Flow direction

Kvs = m<sup>3</sup>/h at a pressure drop of 1 bar and fully open valve.

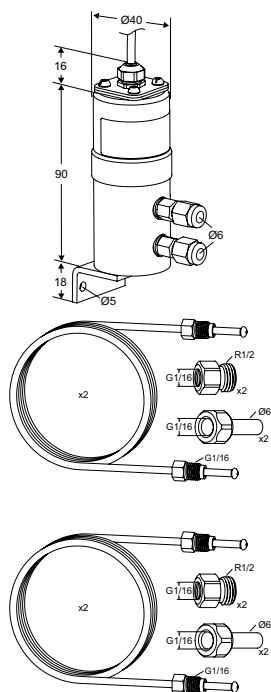

### Dp sensor set

1 differential pressure sensor, 2x1 m capillary pipes Ø6 mm with G1/16 connections, 2 transitions nipples G1/16xG1/2, 2 transitions nipples G1/16xØ6.

	$\Delta p_{burst}$	Kg	EAN	Article No
<b>10-100 kPa</b>	500 kPa	0,43	5902276817656	325020-10008
<b>40-400 kPa</b>	1200 kPa	0,43	5902276817663	325020-10009

$\Delta p_{burst}$  = Maximum differential pressure that may be applied to the sensor.

### Connection set

2x1 m capillary pipes Ø6 mm with G1/16 connections, 2 transitions nipples G1/16xG1/2, 2 transitions nipples G1/16xØ6. (Without Dp sensor. Only compatible with IMI type of Dp sensor)

	EAN	Article No
	5902276817670	326040-10001

## Accessories

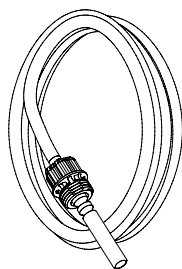

### Temperature sensor

Included in TA-Smart/-Dp. Tool for exchanging temperature sensor is included.

For DN	Length [m]	EAN	Article No
20-25	3	7318794178229	322230-01106
32-50	3	7318794173705	322230-01100
65-125	5	7318794173804	322230-01101

### Temperature sensor pocket

Included in TA-Smart/-Dp DN 65-125. For mounting directly on pipe. Free space >70 mm is required above the temperature sensor pocket.

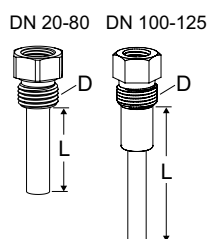

For DN	D	L	EAN	Article No
20-25	G1/4	14	7318794174603	322230-00401
20-25	G1/2	14	7318794178199	322230-00403
32-80	G1/4	30	7318794174009	322230-00400
32-80	G1/2	30	7318794178205	322230-00404
100-125	G3/8	58	7318794178175	322230-00402

### Temperature housing incl. temperature sensor pocket and capillary pipe connection

Included in TA-Smart-Dp DN 20-50. To be ordered separately if the pipe size does not match the valve size. Internal threads according to ISO 228.

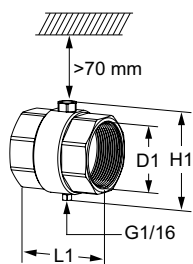

DN	D1	L1	H1	EAN	Article No
20*	G3/4	60	56	7318794174900	322230-00020
25	G1	62	61	7318794175006	322230-00025
32	G1 1/4	66	70	7318794171404	322230-00032
40	G1 1/2	67	76	7318794171503	322230-00040
50	G2	68	89	7318794171602	322230-00050

\*) Can be connected to smooth pipes by KOMBI compression coupling.

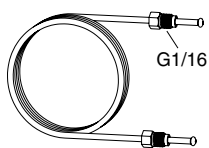

### Capillary pipe

L	EAN	Article No
1 m	7318793661500	52 265-301

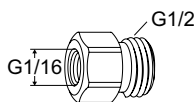

### Transition nipple

For capillary pipe with G1/16 connection.

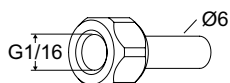

	EAN	Article No
G1/16xG1/2	5902276817878	326040-10003
G1/16xØ6	5902276817861	326040-10002

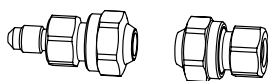

### Extension kit for capillary pipe

Complete with connections for 6 mm pipe

	EAN	Article No
	7318793781505	52 265-212

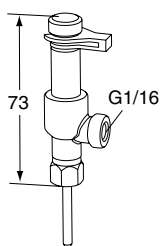

### Measuring point, two-way

For connection of capillary pipe while permitting simultaneous use of our balancing instrument.

	EAN	Article No
	7318793784100	52 179-200

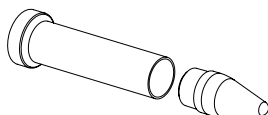

### Service tool

	EAN	Article No
For exchange of temperature sensor	7318794178144	322033-00000
For exchange of TA-Slider cable	7318794178151	322033-00001

### Insulation

For heating and non-condensing cooling applications.

Material: EPP.

Fire class: E (EN 13501-1), B2 (DIN 4102).

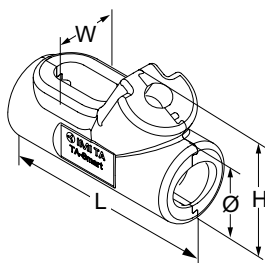

For DN	L	H	W	Ø	EAN	Article No
20	215	112	76	69	5902276819681	322230-00620
25	225	119	86	82	5902276819698	322230-00625
32	238	153	92	96	5902276819438	322230-00632
40	256	168	110	114	5902276819360	322230-00640
50	284	183	134	143	5902276819377	322230-00650

## Connections

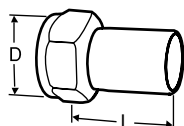
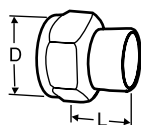
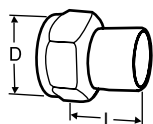
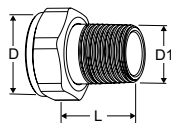
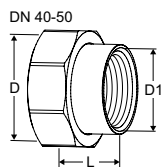
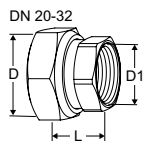

### With internal thread

Threads according to ISO 228. Thread length according to ISO 7-1. Swivelling nut. Brass/AMETAL®

For DN	D	D1	L*	EAN	Article No
20	G1	G3/4	23	7318794017009	52 163-020
25	G1 1/4	G1	23	7318794017108	52 163-025
32	G1 1/2	G1 1/4	31	7318794017207	52 163-032
40	G2	G1 1/2	30	7318794032705	52 163-040
50	G2 1/2	G2	32	7318794032804	52 163-050

### With external thread

Threads according to ISO 7-1. Swivelling nut. Brass

For DN	D	D1	L*	EAN	Article No
20	G1	R3/4	32,5	4024052516810	0601-03.350
25	G1 1/4	R1	35	4024052517015	0601-04.350
32	G1 1/2	R1 1/4	38,5	4024052517213	0601-05.350

### Welding connection

Swivelling nut. Brass/Steel 1.0045 (EN 10025-2)

For DN	D	Pipe DN	L*	EAN	Article No
20	G1	20	40	7318792748608	52 009-020
25	G1 1/4	25	40	7318792748707	52 009-025
32	G1 1/2	32	40	7318792748806	52 009-032
40	G2	40	45	7318792748905	52 009-040
50	G2 1/2	50	50	7318792749001	52 009-050

### Soldering connection

Swivelling nut. Brass/gunmetal CC491K (EN 1982)

For DN	D	Pipe Ø	L*	EAN	Article No
20	G1	18	15	7318792749506	52 009-518
20	G1	22	18	7318792749605	52 009-522
25	G1 1/4	28	21	7318792749704	52 009-528
32	G1 1/2	35	26	7318792749803	52 009-535
40	G2	42	30	7318792749902	52 009-542
50	G2 1/2	54	35	7318792750007	52 009-554

### Connection with smooth end

For connection with press coupling. Swivelling nut. Brass/AMETAL®

For DN	D	Pipe Ø	L*	EAN	Article No
20	G1	18	44	7318793810700	52 009-318
20	G1	22	48	7318793810809	52 009-322
25	G1 1/4	28	53	7318793810908	52 009-328
32	G1 1/2	35	59	7318793811004	52 009-335
40	G2	42	70	7318793811103	52 009-342
50	G2 1/2	54	80	7318793811202	52 009-354

\*) Fitting length (from the gasket surface to the end of the connection).

The products, texts, photographs, graphics and diagrams in this document may be subject to alteration by IMI Hydronic Engineering without prior notice or reasons being given. For the most up to date information about our products and specifications, please visit [www.imi-hydronic.com](http://www.imi-hydronic.com).