

TA-Slider 1600



Actuators

Digitally configurable proportional push-pull actuator
– 1600 N

TA-Slider 1600

Digitally configurable actuators for all control systems with or without Bus communication. Wide range of setup possibilities gives high flexibility to adapt parameters on-site. Fully programmable binary input, relay and adjustable max. stroke of the valve bring new opportunities for advanced hydronic control and balancing.

Key features

- > **Convenient, reliable setup**
Fully customisable by smartphone via Bluetooth using a TA-Dongle.
- > **Easy diagnostics**
Tracks the last 10 errors to allow system faults to be found quickly.
- > **Fully configurable**
More than 200 setup options allow input and output signals, binary input, relay, characteristics and many other parameters to be configured.
- > **Perfection in connectivity**
Communication with the most used Bus protocols.



Technical description

Functions:

Proportional control
3-point control
On-off control
Manual override
Stroke detection
Mode, status and position indication
Output signal VDC
Stroke limitation setting
Minimum stroke setting
Valve blockage protection
Valve clogging detection
Error safe position
Diagnostic/Logging
Delayed start-up

Plus version:

With optional Bus communication board
+ ModBus or BACnet
With optional relay board
+ 1 binary input, max. 100 Ω, cable max. 10 m or shielded.
+ 2 relays, max. 5A, 30 VDC/250 VAC on resistive load
+ Output signal in mA

Supply voltage:

24 VAC/VDC ±15%.
100-240 VAC ±10%.
Frequency 50/60 Hz ±3 Hz.

Power consumption:

24 VAC/VDC:
Operation: < 11.5 VA (VAC); < 5.7 W (VDC)
Standby: < 1.1 VA (VAC); < 0.5 W (VDC)
100-240 VAC:
Operation: < 11.8 VA (VAC)
Standby: < 1.7 VA (VAC)

Input signal:

0(2)-10 VDC, R_i 47 kΩ.
Adjustable sensitivity 0.1-0.5 VDC.
0.33 Hz low pass filter.
0(4)-20 mA R_i 500 Ω.
Proportional:
0-10, 10-0, 2-10 or 10-2 VDC
0-20, 20-0, 4-20 or 20-4 mA
Proportional split-range:
0-5, 5-0, 5-10 or 10-5 VDC
0-4.5, 4.5-0, 5.5-10 or 10-5.5 VDC
2-6, 6-2, 6-10 or 10-6 VDC
0-10, 10-0, 10-20 or 20-10 mA
4-12, 12-4, 12-20 or 20-12 mA
Proportional dual-range (for change-over):
0-3.3 / 6.7-10 VDC,
10-6.7 / 3.3-0 VDC,
2-4.7 / 7.3-10 VDC or
10-7.3 / 4.7-2 VDC.
Default setting: Proportional 0-10 VDC.

Output signal:

0(2)-10 VDC, max. 8 mA, min. 1.25 kΩ.
Plus version:
0(4)-20 mA, max. 700 Ω.
Ranges: See "Input signal".
Default setting: Proportional 0-10 VDC.

Characteristics:

Linear, EQM 0.25 and inverted EQM 0.25.
Default setting: Linear.

Control speed:

3, 4, 6, 8, 12 or 16 s/mm
Default setting: 3 s/mm.

Adjusting force:

1600 N

Temperature:

Media temperature: 0°C – +120°C
Operating environment: 0°C – +50°C
(5-95%RH, non-condensing)
Storage environment: -20°C – +70°C
(5-95%RH, non-condensing)

Ingress protection:

IP 54 (all directions)
(according to EN 60529)

Protection class:

(according to EN 61140).
100-240 VAC: Class I.

24 VAC/VDC: Plus version with optional relay board, Class I. All other versions, Class III safety extra low voltage.

Stroke:

Max. 33 mm

Automatic detection of the valve lift (stroke detection).

Noise level:

Max. 40 dBA

Weight:

1,6 kg

Connection to valve:

By two M8 screws to the valve and by quick connection to the stem.

Material:

Cover: PBT
Bracket: Alu EN44200

Colour:

Orange RAL 2011, grey RAL 7043.

Marking:

IMI TA, product name, article No. and technical specification.
LED indication description.

Certification CE:

LV-D. 2014/35/EU: EN 60730-1, -2-14.
EMC-D. 2014/30/EU: EN 60730-1, -2-14.
RoHS-D. 2011/65/EU: EN 63000.

Product standard:

EN 60730.
(for Residential and industrial areas)

Cable:

Wire cross-section*: 0.5-2.0 mm²
Protection class I: H05VV-F or similar
Protection class III: LiYY or similar

*) **Note:** Wire cross-sections must be chosen according to actuator power consumption and line length, such as the voltage supply to the actuator does not go below 20.4 VAC/VDC (24 VAC/VDC minus 15%).

In case of VDC input signal on a 24 VAC/VDC powered actuator, the voltage drop on neutral line must be smaller than the defined hysteresis level for the VDC input signal.

Function

Setting

The actuator can be set by the HyTune app (iOS version 8 or later on iPhone 4S or later, Android version 4.3 or later) + the TA-Dongle device, with or without the actuator power supplied. The setting configuration can be stored in the TA-Dongle for setting of one or several actuators. Connect the TA-Dongle to the actuator and press the configuration button. HyTune can be downloaded from the App Store or Google Play.

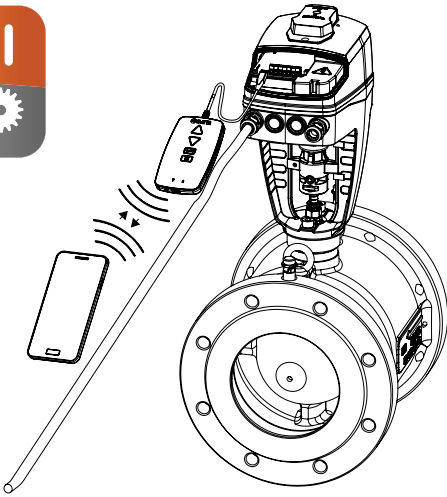

Setting Bus communication parameters

Configuration of Bus parameters such as address, baud rate, parity and more is to be carried out by the HyTune app + the TA-Dongle device, with or without the actuator power supplied. More detailed information, please see Bus protocol implementation documents.

Manual override

By 5 mm Allen key or by the TA-Dongle device.

Note: Power supply needed when TA-Dongle is used.

Position indicator

Visible mechanical stroke indication on the bracket.

Calibration/Stroke detection

According to selected settings in the table.

Type of calibration	At power on	After manual override
Both end positions (full)	√ *	√
Fully extended position (fast)	√	√ *
None	√	

*) Default

Note: A calibration refresh can be automatically repeated monthly or weekly.

Default setting: Off.

Stroke limitation setting

A maximum stroke smaller than or equal to the detected valve lift can be set to the actuator.

For some TA/HEIMEIER valves it can also be set to a Kv_{max}/q_{max} .
Default setting: No stroke limitation (100%).

Minimum stroke setting

The actuator can be set with a minimum stroke below which it will not go (except for calibration).

For some TA/HEIMEIER valves, it can also be set to a q_{min} .

Default setting: No minimum stroke (0%).

Valve blockage protection

The actuator will perform a quarter of a full stroke and then back to desired value if no actuation takes place for one week or one month.

Default setting: Off.

Valve clogging detection

If actuation stops before the desired value is reached, the actuator moves back ready to make a new attempt. The actuator will move to the configured error safe position after three attempts.

Default setting: On.

Error safe position

Fully extended or retracted position when following errors occur; low power, line break, valve clogging or stroke detection failure.

Default setting: Fully extended position.

Diagnostics/logging

The last 10 errors (low power, line break, valve clogging, stroke detection failure) with time stamps can be read using the HyTune app + TA-Dongle device. Logged errors will be cleared if the power is disconnected.

Delayed start-up

The actuator can be specified a delay (0 to 1275 sec.) before starting up after a power supply cut. This is useful when used with a control system that has itself a long start-up time.

Default setting: 0 seconds.

Plus version:

Connection interfaces for Bus communication

- RS485; BACnet MS/TP, Modbus/RTU
- Ethernet; BACnet/IP, Modbus/TCP

Binary input

If the binary input circuit is open, the actuator will go to a set stroke, switch to a second stroke limitation setting or drive to its full stroke regardless of any limitations for flushing purpose. See also Change-over system detection.

Default setting: Off

Change-over system detection

Switching between two different stroke limitation settings by toggling the binary input or using the dual-range input signal.

For the Bus versions, this switching may also be made via the Bus.

LED indication

	Status	Green
	Fully retracted (actuator stem)	Long pulse - Short pulse
	Fully extended (actuator stem)	Short pulse - Long pulse
	Intermediate position	Long pulses
	Moving	Short pulses
	Calibrating	2 short pulses
	Manual mode or no power supply	Off

	Error code	Red
	Power supply too low	1 pulse
	Line broken (2-10 V or 4-20 mA)	2 pulses
	Valve clogging or foreign object	3 pulses
	Stroke detection failure	4 pulses

If an error is detected, red pulses are displayed as the green status lights flash alternately. More detailed information, please see the HyTune app + TA-Dongle.

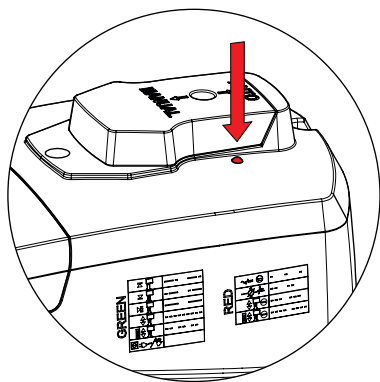

Installation

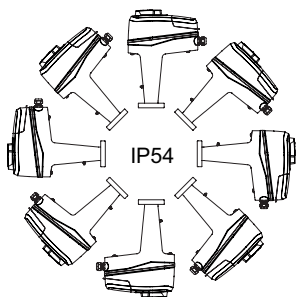

Note!

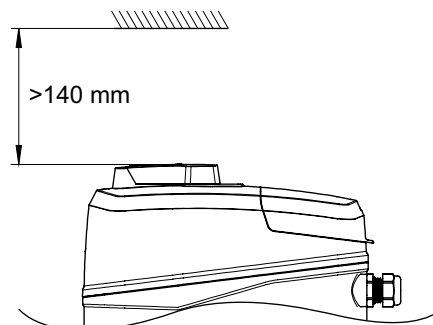

Connection diagram – Terminal/Description

Terminal	Description
L24	Power supply 24 VAC/VDC
M*	Neutral for power supply 24 VAC/VDC and signals
L	Power supply 100-240 VAC
N	Neutral for power supply 100-240 VAC
Y _i	Input signal for proportional control 0(4)-20 mA, 500 Ω
Y _v	Input signal for proportional control 0(2)-10 VDC, 47 kΩ
X _i	Output signal 0(4)-20 mA, max. resistance 700 Ω
X _v	Output signal 0(2)-10 VDC, max. 8 mA or min. load resistance 1.25 kΩ
Dw	3-point control signal for extending actuator spindle (24 VAC/VDC or 100-240 VAC)
Up	3-point control signal for retracting actuator spindle (24 VAC/VDC or 100-240 VAC)
B	Connection for potential free contact (e.g. open window detection), max. 100 Ω, max. 10 m cable or shielded
COM1, COM2	Common relay contacts, max. 250 VAC, max. 5A @ 250 VAC on resistive load, max. 5A @ 30 VDC on resistive load
NC1, NC2	Normally closed contacts for relays 1 and 2
NO1, NO2	Normally open contacts for relays 1 and 2

*) All M terminals are internally connected.

Connection diagram – 24 V

0(2)-10 VDC

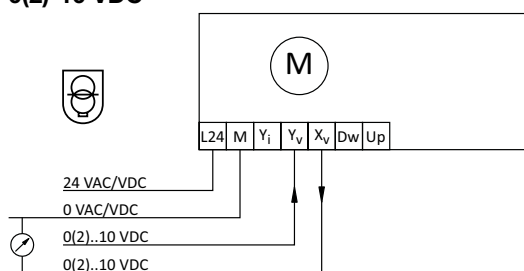

3-point

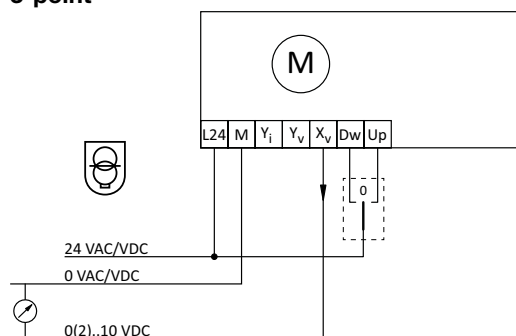

0(4)-20 mA

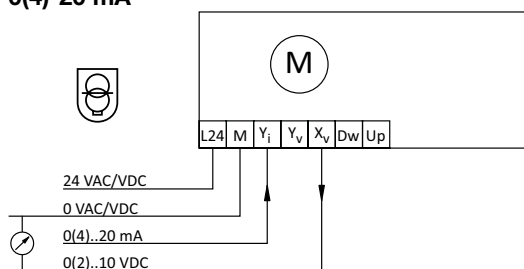

On-off

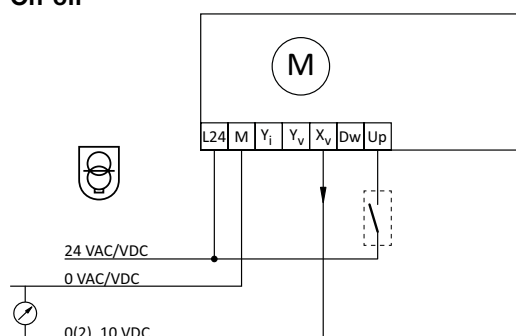

24 VAC/DC operating only with safety transformer according EN 61558-2-6

Connection diagram – 100-240 V

0(2)-10 VDC

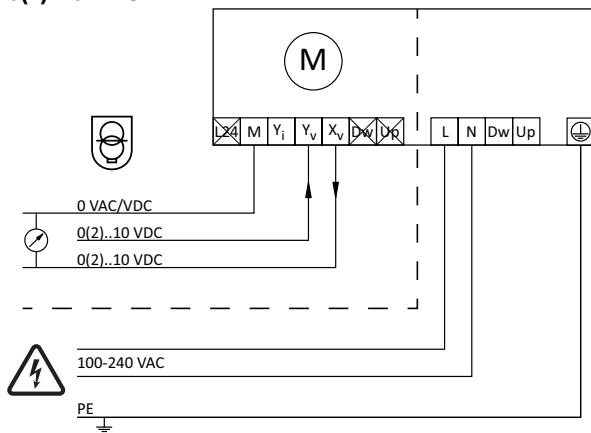

3-point

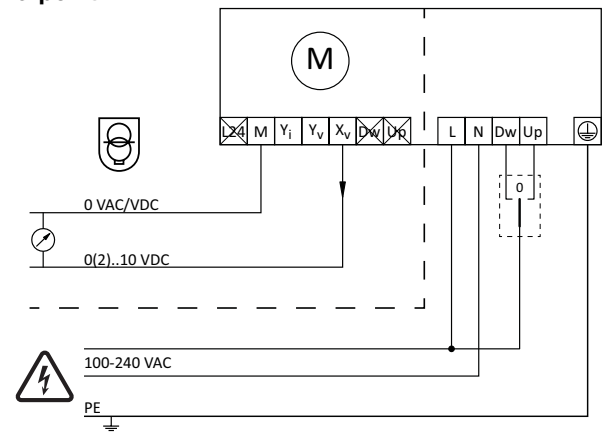

0(4)-20 mA

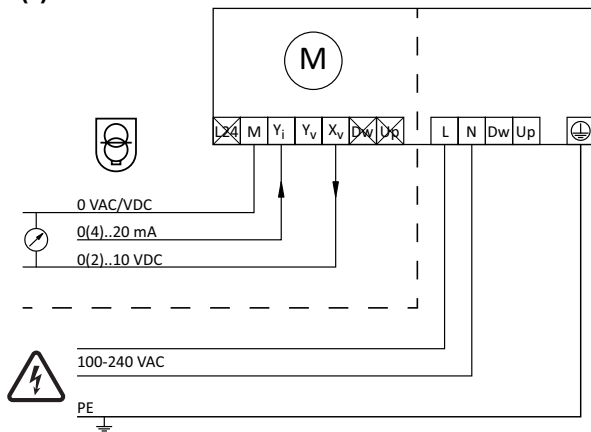

On-off

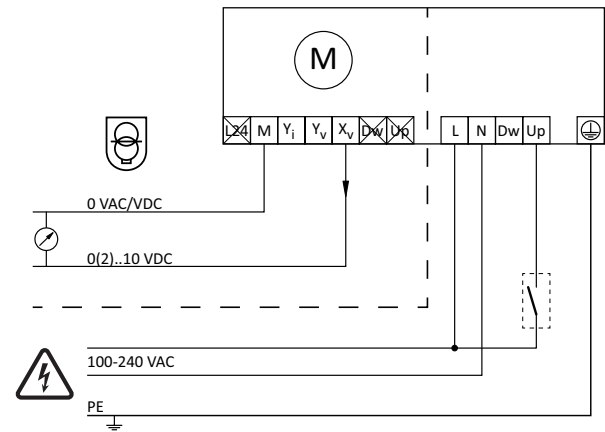

24 VAC/DC operating only with safety transformer according EN 61558-2-6

Connection diagram – Relay (for Plus version only)

Optional relay board

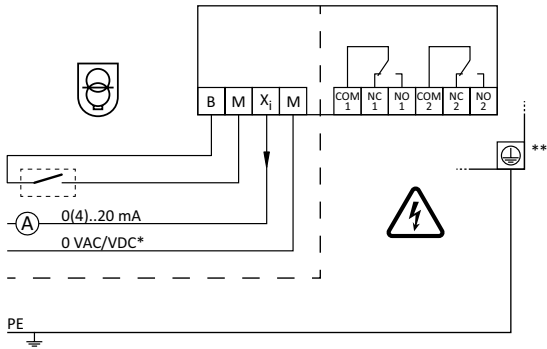

*) Low voltage neutral

**) Ground connection required.

Connection diagram – Bus communication (for Plus version only)

Optional Ethernet communication board

BACnet/IP, Modbus/TCP

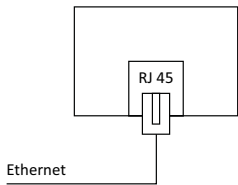

Optional RS 485 board

BACnet MS/TP, Modbus/RTU

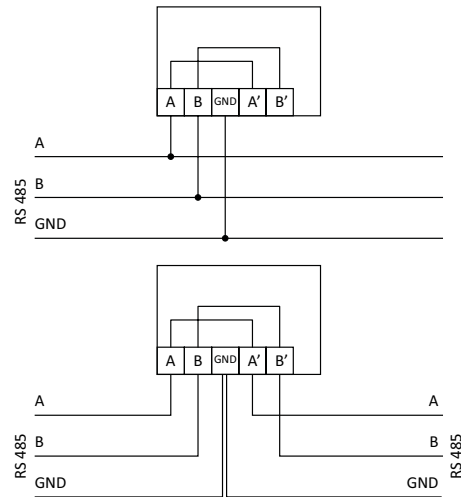

Note: A, B, A', B' and GND terminals are isolated from all other terminals.

Articles

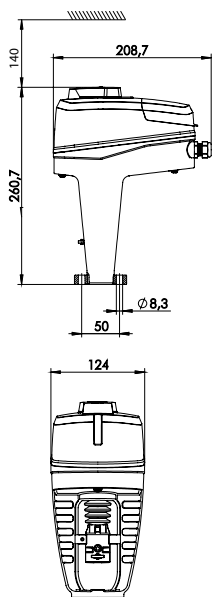

TA-Slider 1600

Input signal: 0(2)-10 VDC, 0(4)-20 mA, 3-point, on-off

Supply voltage	EAN	Article No
24 VAC/VDC	5902276816789	322228-10110
100-240 VAC	5902276816796	322228-40110

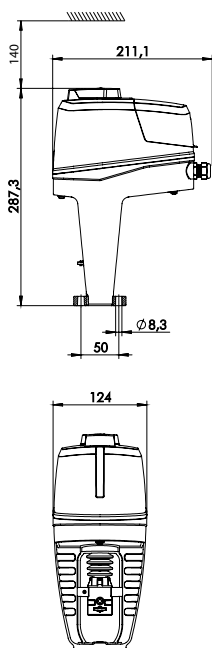

TA-Slider 1600 Plus

Input signal: 0(2)-10 VDC, 0(4)-20 mA, 3-point, on-off

With binary input, relays, mA output

Supply voltage	Bus	EAN	Article No
24 VAC/VDC	-	5902276816802	322228-10219
100-240 VAC	-	5902276816819	322228-40219

With BUS communication (without binary input, relays, mA output)

Supply voltage	Bus	EAN	Article No	
24 VAC/VDC	Modbus/RTU	RS 485	5902276816826	322228-12210
	BACnet MS/TP	RS 485	5902276816833	322228-13210
	Modbus/TCP	Ethernet	5902276816840	322228-14210
	BACnet/IP	Ethernet	5902276816857	322228-16210
100-240 VAC	Modbus/RTU	RS 485	5902276816864	322228-42210
	BACnet MS/TP	RS 485	5902276816871	322228-43210
	Modbus/TCP	Ethernet	5902276816888	322228-44210
	BACnet/IP	Ethernet	5902276816895	322228-46210

With BUS communication, binary input, relays, mA output

Supply voltage	Bus	EAN	Article No	
24 VAC/VDC	Modbus/RTU	RS 485	5902276816901	322228-12219
	BACnet MS/TP	RS 485	5902276816918	322228-13219
	Modbus/TCP	Ethernet	5902276816925	322228-14219
	BACnet/IP	Ethernet	5902276816932	322228-16219
100-240 VAC	Modbus/RTU	RS 485	5902276816949	322228-42219
	BACnet MS/TP	RS 485	5902276816956	322228-43219
	Modbus/TCP	Ethernet	5902276816963	322228-44219
	BACnet/IP	Ethernet	5902276816970	322228-46219

Additional equipment

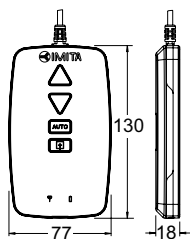

TA-Dongle

For Bluetooth communication with the HyTune app, transfer configuration settings and manual override.

EAN

5901688828632

Article No

322228-00001

Accessories

Stem heater

Including spindle top (extension) and extended screws.

Temperature range till -10°C .

Voltage 24 VAC $\pm 10\%$, 50/60 Hz $\pm 5\%$.

Power P_N approx. 30 W.

Current 1,4 A.

Surface temperature max. 50°C .

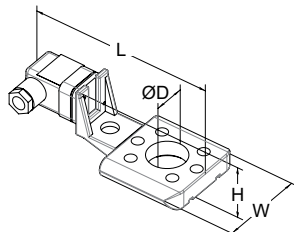

For valve	DN	L	H	W	D	EAN	Article No
		146	49	70	30		
KTM 512	65-125					3831112533455	322042-81401
TA-Modulator	65-200					3531112534834	322052-80010