

EFP® Electronic Foam Proportioner



The EFP® is an incredibly accurate electronically controlled wide range foam proportioning system.

The EFP is an easy to maintain and easy to test fire safety system for the safe storage of combustible substances and flammable liquids. The EFP has a proportion accuracy of 0,1% around the required mixing ratio without any pressure losses in the water flow. With only two control valves, the CPU automatically measures the systems performance every 24 hours.

The internal test facility enables you to test the EFP on an annual or even weekly base without mixing the foam concentrate with water. With no loss of foam concentrate, nor environmental damage while testing the EFP creates a significant reduction in costs for maintenance.

Main features

- ✓ Proportioning accuracy is maintained regardless of temperature or viscosity of the foam concentrate.
- ✓ The mixing accuracy of 0,1% around the required mixing ratio.
- ✓ Test provisions to test the system on a yearly (or even weekly) basis according to NFPA rules, without actually mixing foam concentrate with water. So no loss of foam concentrate, no environmental damage and significant reduction in costs.
- ✓ A wide range of flow conditions while dosage accuracy is maintained.
- ✓ Zero pressure loss in the water system.
- ✓ <FM> approved versions are available.

Function

The EFP® is an incredibly accurate electronically controlled wide range foam proportioning system. The principle function of the EFP® is the accurate measurement of both the foam concentrates and the water supply with electromagnetic flow meters (EMF).

The EFP®'s heart, the central processing unit (CPU), measures out the correct amount of foam concentrate required for the proportioning and continually monitors the amount of foam mixed in. Two electronic valves control the flow at all times and maintain proper foam pressure.

The EFP® is designed to achieve the required proportioning stability within 30 seconds from start-up in a typical system. With several applications, a response time of 10 seconds was achieved. Such a quick response time ensures the least amount of water spread across the fire, which improves foam efficiency.

The EFP® is equipped with a test facility which enable the operator to test the system without proportioning foam concentrate into the water flow. These types of tests can be executed alongside the Firepacks trails on a weekly basis. In test mode, by switching on the testing valves, the foam concentrate measured and regulated by the EFP® is transferred back to the reservoir.

In designing the EFP®, the 'fail-safe philosophy' as employed in extinguishing systems were vital. Consequentially, the entire construction is based on established components from the process industry. Besides this, all piping is stainless steel and only flange connection are employed.

The EFP® operates on a 24-volt DC power supply allowing the use of back-up power supplies such as diesel Firepacks or battery packs. The EFP® CPU continually monitors and analyses its own functioning on all cable connection. Every 24 hours both electronic valves are opened and closed completely from rest position in order to prevent them sticking together.

The EFP® is certified and meets many regulations such as NFPA, VAS, CEA and VdS.

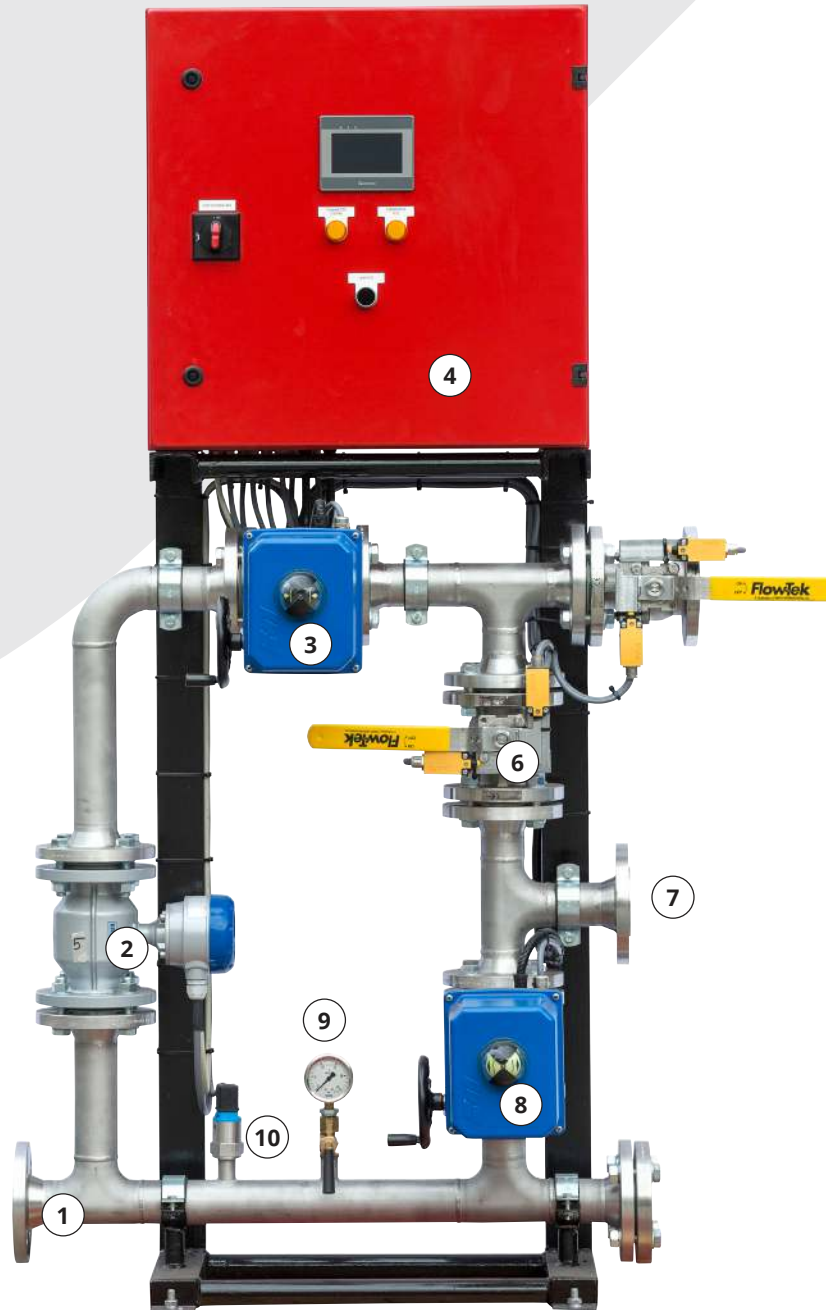

Construction

1. Connection foam pump(s)
2. Flowmeter foam concentrate
3. Flow control valve foam concentrate
4. Touchscreen controller
5. Manual test valve in the high-pressure pipe with built-in limit-switch. Position shown is operational
6. Manual test valve in the return pipe with built-in limit-switch. Position shown is operational
7. Connection for return pipe to foam concentrate reservoir
8. Pressure control valve foam concentrate
9. Manometer
10. Pressure transducer foam concentrate

Function diagram

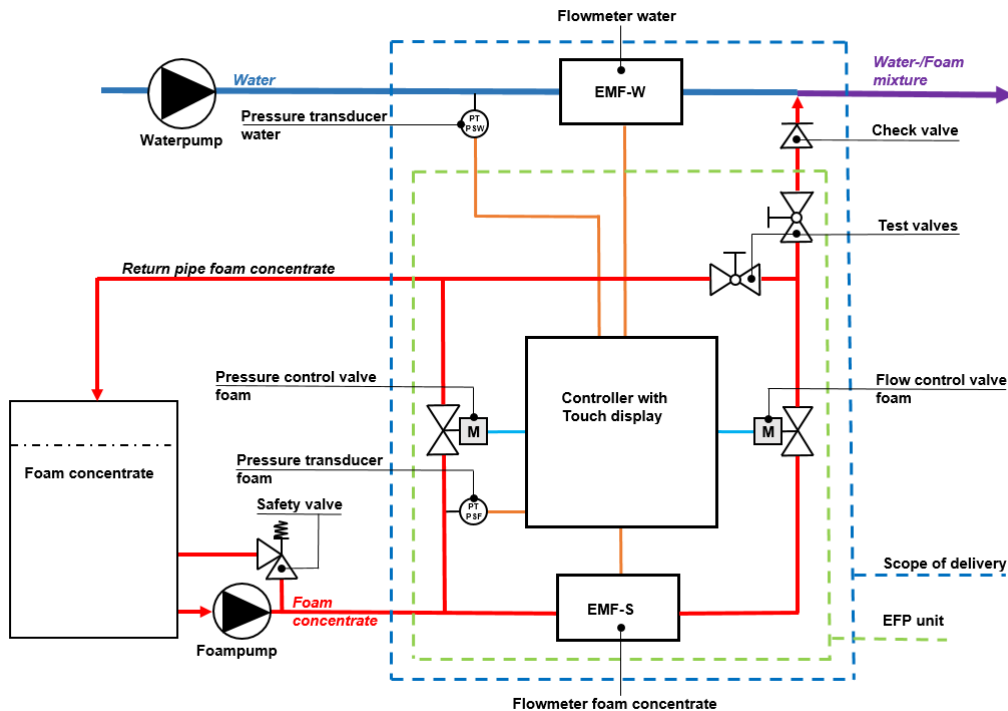

Technical specifications

Working principle	: Closed loop based on EMF-flow meters
Controls	: Siemens PLC
Flow meter	: Krohne EMF (for foam and water circuits)
Pressure sensors	: Endress & Hauser, 0-25 bar, 4-20 mA
Regulation valves	: Regulation ball valves DN 40 or DN 50
Start-up time	: 0 - 100% in 8 seconds
Construction	: DN 50, 316 stainless steel, flange connections
Monitor function	: - continual monitoring - daily automatic functionality testing of the regulation valves - test valves equipped with limit-switch - when operational, constant monitoring of amount and pressure
Alert	: Request by fire alarm or pump controller
Potential-free contacts	: Test valves in test position, general malfunctions
Power supply	: 24-volt DC (from pump controller), optional power supply 1 ~ 230 volt 50 Hz and/or UPS
Proportioning ratio	: 0,5 - 6%
Foam concentrate pressure	: max. 25 bar (360 psi)
Proportioning accuracy	: Within 0,1% of the selected a proportioning ratio
Certification	: <FM> certification (optional)
Dimensions	: Width x height x depth = 920 x 1650 x 532 mm
Operational temperature	: 4 ... 55 ° C
Dynamic viscosity (<FM>)	: 1 ... 4000 cP (21 ° C) (1 cP = 1 g / (cm · s))

Performance

Description	Performance foam concentrate	
	min. (m ³ /h)	max. (m ³ /h)
EFP-NLS (non-listed)	0,8	27
EFP-NLH (non-listed)	1,6	50
EFP-FMS (FM-approved)	0,8	27
EFP-FMH (FM-approved)	1,6	34

Dimensions

