

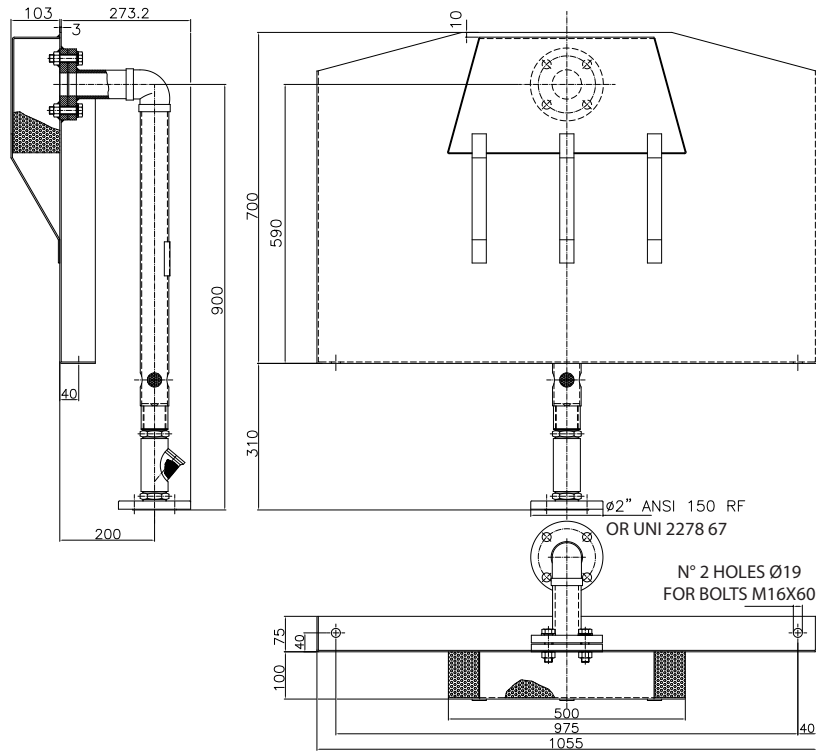

Discharge Devices & Nozzles | Tank Protection | FR Foam Maker



SPECIFICATIONS	
Related Documents	None available
Materials	Carbon or stainless steel AISI 316
Connection Type	Flange PN16 or ANSI
Finish	Red epoxy (Flame red RAL3000)
Finish (Optional)	Galvanised or painted



Base part number	Ø Inlet (inch)	Ø Outlet (inch)	Flow rate (l/min - 5 bar)	Foam production (l/min - 5 bar) ^{1,2}	Working pressure (bar)	Weight (kg)
EFR02	2	3	200	1,500	3 - 12	55
EFR04	2	4	400	3,000	3 - 12	55
EFR08	3	6	800	6,000	3 - 12	60
EFR15	4	8	1,500	11,000	3 - 12	80
EFR20	4	8	2,000	14,000	3 - 12	83

¹ Depending on the foam concentrate used. For actual expansion performance data, tests with device and selected foam concentrate should be conducted
² The indicated production is obtained with fresh air, or otherwise indicated by the manufacturer

Part number selection - Add flange style and finish designation: Flange type:- P=PN16 or A=ANSI; Finish:- P=Painted, G=Galvanised, M=Galvanised & coated red, R=SS304 with red paint finish, S=SS316 with red paint finish); Example:- EFR20PS = Foam pourer with 4" PN16 flange with galvanised and red paint finish

Note: This document contains basic product information only. Information, photos and drawings are not contractually binding. In all cases, the manufacturer's full technical documentation (see "Related Documents" above) remains the reference document. Note that certificates, test reports and approvals may be published in the OEM name. The contents of this publication are subject to modifications without notice. All rights reserved

Trusted above all.

Viking S.A. (ed.) | 21, Z.I. Haneboesch | L-4562 Differdange/Niederborn | Luxembourg | vikinglux@viking-emea.com | www.viking-emea.com

