





Monitor Equipment | Manual Monitor | MH Handwheel Operated Monitor



Model MH2 with 1 handwheel x 1 knob shown

SPECIFICATIONS

| | |
|-------------------------|---|
| Related documents | None available |
| Approvals |    |
| Material (Body) | Stainless steel AISI 316 |
| Material (Joints) | Stainless steel AISI 316, Phosphor bronze balls |
| Material (Flange) | Carbon steel or stainless steel |
| Working pressure (Max.) | 16 bar* |
| Finish | Red epoxy (Flame red RAL3000) |
| Connection type | Flange PN16 |
| Rotation | 360° continuous |
| Swivels | See table |
| Options | <ul style="list-style-type: none"> Polished stainless steel finish +85° elevation angle ANSI flanges |
| Weight | See table |

*** Note:**
Lower working pressures may need to be assessed based upon how the monitor is operated, supported and where installed. Please refer to recoil force table for further information.

| Part number* | Vertical swivel | Horizontal swivel | ØD1 (inch) PN16 | Flange material | ØD2 (inch) BSP | Max. flow rate (l/min) | Weight (kg) |
|---|-----------------|-------------------|-----------------|-----------------|----------------|------------------------|-------------|
| 3" Stainless steel body (1 handwheel) | | | | | | | |
| EMH2-3X3CPS | Handwheel | Knob | 3" | Carbon steel | 3" | 4,000 | 24.0 |
| EMH2-3X3SPS | Handwheel | Knob | 3" | Stainless steel | 3" | 4,000 | 24.0 |
| EMH2-3X4CPS | Handwheel | Knob | 4" | Carbon steel | 3" | 4,000 | 25.0 |
| EMH2-3X4SPS | Handwheel | Knob | 4" | Stainless steel | 3" | 4,000 | 25.0 |
| 4" Stainless steel body (1 handwheel) | | | | | | | |
| EMH2-4X4CPS | Handwheel | Knob | 4" | Carbon steel | 4" | 8,000 | 26.0 |
| EMH2-4X4SPS | Handwheel | Knob | 4" | Stainless steel | 4" | 8,000 | 26.0 |
| EMH2-4X6CPS | Handwheel | Knob | 6" | Carbon steel | 4" | 8,000 | 27.0 |
| EMH2-4X6SPS | Handwheel | Knob | 6" | Stainless steel | 4" | 8,000 | 27.0 |
| 3" Stainless steel body (2 handwheels) | | | | | | | |
| EM2H2-3X3CPS | Handwheel | Handwheel | 3" | Carbon steel | 3" | 4,000 | 34.0 |
| EM2H2-3X3SPS | Handwheel | Handwheel | 3" | Stainless steel | 3" | 4,000 | 34.0 |
| EM2H2-3X4CPS | Handwheel | Handwheel | 4" | Carbon steel | 3" | 4,000 | 35.0 |
| EM2H2-3X4SPS | Handwheel | Handwheel | 4" | Stainless steel | 3" | 4,000 | 35.0 |
| 4" Stainless steel body (2 handwheels) | | | | | | | |
| EM2H2-4X4CPS | Handwheel | Handwheel | 4" | Carbon steel | 4" | 8,000 | 37.0 |
| EM2H2-4X4SPS | Handwheel | Handwheel | 4" | Stainless steel | 4" | 8,000 | 37.0 |
| EM2H2-4X6CPS | Handwheel | Handwheel | 6" | Carbon steel | 4" | 8,000 | 38.0 |
| EM2H2-4X6SPS | Handwheel | Handwheel | 6" | Stainless steel | 4" | 8,000 | 38.0 |

*For polished stainless steel finish - substitute final "S" of part number with an "X" (Example EM2H2-4X6SPX)

Note: This document contains basic product information only. Information, photos and drawings are not contractually binding. In all cases, the manufacturer's full technical documentation (see "Related Documents" above) remains the reference document. Note that certificates, test reports and approvals may be published in the OEM name. The contents of this publication are subject to modifications without notice. All rights reserved

Trusted above all.

Viking S.A. (ed.) | 21, Z.I. Haneboesch | L-4562 Differdange/Nieder Korn | Luxembourg | vikinglux@viking-emea.com | www.viking-emea.com





Monitor Equipment | Manual Monitor | MH Handwheel Operated Monitor

EMH2-3X

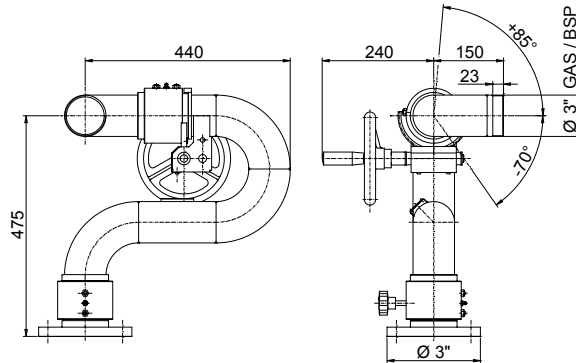

EM2H2-3X

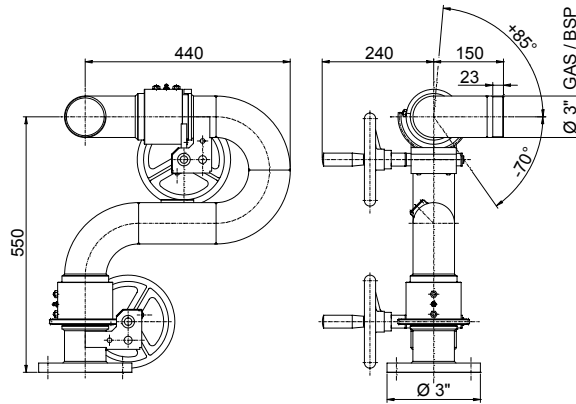

EMH2-4X

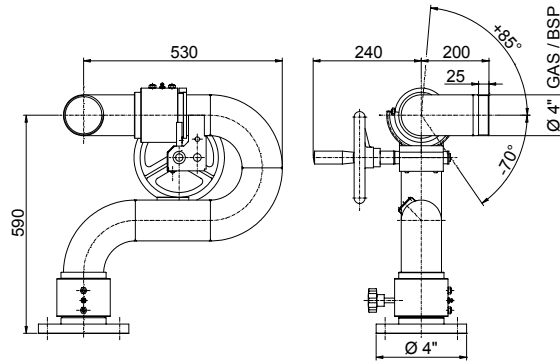

EM2H2-4X

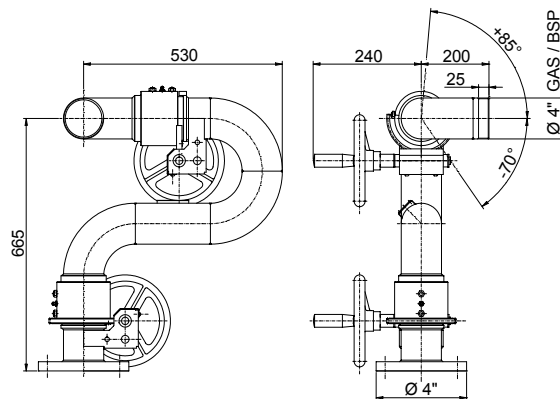

DIMENSIONS ARE IN MM

Note: This document contains basic product information only. Information, photos and drawings are not contractually binding. In all cases, the manufacturer's full technical documentation (see "Related Documents" above) remains the reference document. Note that certificates, test reports and approvals may be published in the OEM name. The contents of this publication are subject to modifications without notice. All rights reserved

Trusted above all.

Viking S.A. (ed.) | 21, Z.I. Haneboesch | L-4562 Differdange/Nieder Korn | Luxembourg | vikinglux@viking-emea.com | www.viking-emea.com

