

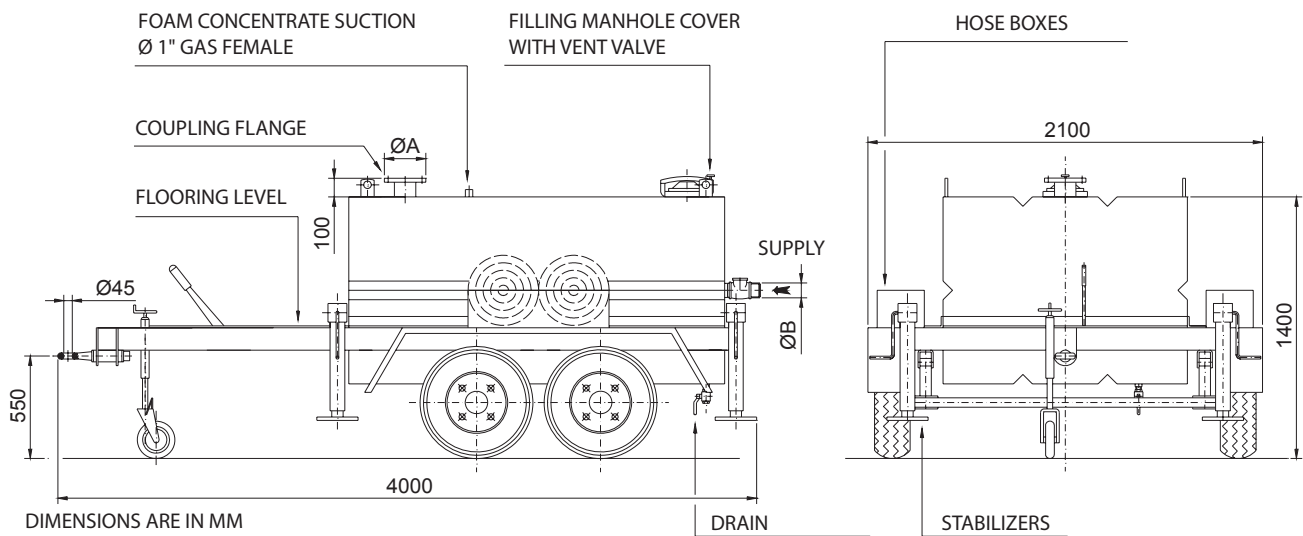

Trailers & Towers | Monitor Trailers & Carts | MT Monitor Trailer & Tank | 4 Wheel



SPECIFICATIONS	
Related Documents	None available
Approvals	
Materials	Carbon steel structure and hose boxes - Rubber tires
Finish	Red epoxy paint (Flame red RAL3000)
Working pressure	16 bar* (Max.)
Max. Flow	6,000 l/min @ 7 bar
Maximum Speed	40 km/h
Options	<ul style="list-style-type: none"> Tank in AISI 304 or AISI 316 or with different sizes Leaf spring suspension Rubber torsion bar suspension Lights Trailer approved for public use** Different feed connection types (STORZ, BSS, etc.)
<p>* Lower working pressures may need to be assessed based upon how the monitor is operated, supported and where installed. Please refer to recoil force table for further information. ** Standard trailer is not approved for public use. Customer to provide local requirements for public use so an assessment can be made if trailer can be adapted road legal in selected country.</p>	



Part number	ØA (inch)	ØB (inch) (UNI70)	Tank volume (l)	Tank material	Weight (kg)
EMT20004R3	3"	2 x 2-1/2"	2,000	Carbon steel	430
EMT20004R4	4"	3 x 2-1/2"	2,000	Carbon steel	440
EMT25004R3	3"	2 x 2-1/2"	2,500	Carbon steel	490
EMT25004R4	4"	3 x 2-1/2"	2,500	Carbon steel	500
EMT20004R3R	3"	2 x 2-1/2"	2,000	Stainless steel AISI 304	430
EMT20004R4R	4"	3 x 2-1/2"	2,000	Stainless steel AISI 304	440
EMT25004R3R	3"	2 x 2-1/2"	2,500	Stainless steel AISI 304	490
EMT25004R4R	4"	3 x 2-1/2"	2,500	Stainless steel AISI 304	500

Note: This document contains basic product information only. Information, photos and drawings are not contractually binding. In all cases, the manufacturer's full technical documentation (see "Related Documents" above) remains the reference document. Note that certificates, test reports and approvals may be published in the OEM name. The contents of this publication are subject to modifications without notice. All rights reserved

Trusted above all.

