



TECHNICAL DATA

90° AND 180° GRATE NOZZLE® MODEL GN200

The Viking Corporation, 210 N Industrial Park Drive, Hastings MI 49058

Telephone: 269-945-9501 Technical Services: 877-384-5464 Fax: 269-818-1680 Email: techsvcs@vikingcorp.com

Visit the Viking website for the latest edition of this technical data page www.vikinggroupinc.com

1. PRODUCT DESCRIPTION

The Viking Model GN200/90 and GN200/180 Grate Nozzles® are designed for the protection of aircraft hangars and helipads. The 90° and 180° nozzles are installed on the edge of the helipad and spaced so their discharge will cover the entirety of the helipad. The 90° and 180° nozzles are utilized in aircraft hangars in conjunction with the 360° nozzle where a 360° discharge pattern is not desired (i.e., within 5' of exterior wall or door per NFPA 409). The Grate Nozzle® is an AFFF foam discharge device located at the floor level of an aircraft hangar or helipad. The top of the nozzle grate must be flush or level with floor it is protecting. The Grate Nozzle® is designed to discharge foam solution in a 90° (GN200/90), and 180° (GN200/180) radius, respectively. The Grate Nozzle® is designed to provide a uniform discharge. The companion Model 1120 or Model 1126 trench drain grate is specially engineered to receive the Grate Nozzle® and serve as a cover for the drain trench.

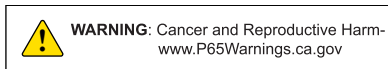

A. Features:

1. Grate Nozzle

- A. The Grate Nozzle spreads AFFF foam solution over the burning liquid faster than conventional overhead deluge foam systems or oscillating monitors because the Grate Nozzles are located where the flammable liquid spill will happen, at the floor.
- B. 2" grooved inlet for simple installation and removal.
- C. Durable construction designed for maximum direct load of 350 PSI over surface area of assembly, (designed to withstand load of airplane parked over Grate Nozzle).
- D. The Grate Nozzle has no moving parts. The spray pattern is developed from its installed position.
- E. Grate Nozzles are located in trench drains so valuable floor space is left for aircraft storage and servicing. The Grate Nozzle discharges foam solution at the floor level in the same location that a fuel spill will occur. The location of Grate Nozzles eliminates the need for expensive underwing oscillating monitors.
- F. The Grate Nozzle has been tested for obstruction to discharge such as aircraft tires, 55 gallon barrels, 3/4" rubber hoses, construction materials, with little effect on time of floor coverage. Grate Nozzles have been covered during discharge, (such as would happen if an airplane tire were parked over it), only to have Grate Nozzles located in the same supply piping increase their flow rate and make up the discharge area lost by the covered Grate Nozzle.
- G. The Grate Nozzle system can also be used for floor wash-down as well. Operating the floor nozzle system without foam solution is a superb method of operating fire protection systems as per NFPA 25 requires, as well as determining if Grate Nozzles require cleaning.
- H. Maximum height of spray pattern above floor is 12" - 18".

2. Model 1120 and Model 1126 trench drain grate

- A. The Model 1120 and Model 1126 trench drain grate are designed as a receiver for the Grate Nozzle.
- B. The Model 1120 and Model 1126 trench drain grate is placed in line with other lengths of trench drain grates to provide a uniform floor and trench drain level.
- C. The Model 1120 and Model 1126 trench drain grate are designed to blend with existing and new trench drain installation.
- D. Grate drain slots in the Model 1120 and Model 1126 trench drain grate are of uniform size with standard grating to enable drainage to occur at the special grate placement.

2. LISTINGS AND APPROVALS



UL Listed - Guide GFUT

US DOD Acceptance

* UL Listing applies when using the following Chemguard Foam Concentrates:

- Chemguard C1B 1% AFFF
- Chemguard C306-MS-C 3% AFFF
- Chemguard C334-LV 3% AR AFFF
- National Foam Aer-o-water 3EM AFFF
- National Foam Aer-o-lite 3% AFFF



TECHNICAL DATA

90° AND 180°
GRATE NOZZLE®
MODEL GN200

The Viking Corporation, 210 N Industrial Park Drive, Hastings MI 49058

Telephone: 269-945-9501 Technical Services: 877-384-5464 Fax: 269-818-1680 Email: techsvcs@vikingcorp.com

Visit the Viking website for the latest edition of this technical data page www.vikinggroupinc.com

3. TECHNICAL DATA

Specifications:

K-Factor:

Model GN200/090: 7 (100 metric)

Model GN200/180: 12 (173 metric)

Recommended Discharge Pressure: 40-60 PSI

Deflector Retaining Allen Bolt: Minimum torque req'd - 45 ft. /lbs.

Material Standards:

Model GN/200 Grate Nozzle: 316L Stainless steel.

Model 1120 and Model 1126 trench drain grate: Cast ductile iron, ASTM A536 Grade 80-55-06

(Refer to Figures 3 & 4 for illustration of Grate Nozzle in trench drain grate) del GN200/180: 12 (17.3 metric)

Ordering Information: (Manufactured since 2006)

Model 1120/GN200/090, Part No. F13687

Model 1126/GN200/090, Part No. F13686

Model 1120/GN200/180, Part No. F13690

Model 1126/GN200/180, Part No. F13689

(Grate included with nozzle)

Shipping Weight:

20" Grate - 105 lbs

26" Grate - 130 lbs.

Available to Order Separately:

"X" Frame Support Package (Class 35B Cast Iron): Part No. 17525 (Note: 1 "X" Frame Support Package is required and included with each grate nozzle)

4. INSTALLATION

Note: Minimum concrete grade shall be 4500 PSI compression load. This is to stand maximum design load of grate assembly.

- A. The water or foam/water solution supply to Grate Nozzles must be continuous, clean, and obstruction free.
- B. Viking Grate Nozzles are only to be installed with the companion Viking trench drain grate. The Grate Nozzle and Viking trench drain grate were designed to work in concert with each other.
- C. Installation of Grate Nozzles or trench drain grates require that adequate trench drain sizing has been accounted for. Trench drain size should be investigated by the architect or engineer prior to installation.
- D. The Grate Nozzle is provided with a 2" grooved inlet for ease of installation and removal.
- E. Supply piping must be located in the trench. A 2" supply pipe should be piped horizontally from the supply main located in the trench, and then vertically to the Grate Nozzle. The 2" supply must terminate in a grooved connection to allow for installation to the Grate Nozzle. The supply piping must be self supporting.
- F. Install wye-type strainers with isolation valves upstream of the riser. Strainers are to be Stainless Steel with a mesh screen no greater than 1/16" perforation.

Spacing of Grate Nozzles

1. Refer to Figures 2a & 2b for an example of spacing Grate Nozzles. Standard practice is to locate the Grate Nozzles so that the maximum distance between nozzles in a trench is 25' and that trench drains are not located in excess of 50' on center, (20' maximum from walls). Configurations other than this may be acceptable, contact Viking for designs other than what is indicated.
2. Grate Nozzles should be installed so that a particular building feature such as a column or raised floor does not cause an obstruction to discharge to the Grate Nozzle.
3. The "X" frame furnished with the Grate Nozzle assembly shall be set in concrete using re-rod as shown in Figure 5. Positioning must be flush with floor, aligned for bolting of grate to frame and placed to accommodate the remaining grate drainage system.

**TECHNICAL DATA****90° AND 180°
GRATE NOZZLE®
MODEL GN200**

The Viking Corporation, 210 N Industrial Park Drive, Hastings MI 49058

Telephone: 269-945-9501 Technical Services: 877-384-5464 Fax: 269-818-1680 Email: techsvcs@vikingcorp.com

Visit the Viking website for the latest edition of this technical data page www.vikinggroupinc.com

Minimum Trench Drain Dimension

1. The trench drain should be of a minimum dimension of 20" or 26" wide to receive Viking Grate.
2. Trench drains will vary in length due to hangar dimensions, but the trench length shall be such that a Grate Nozzle can be located half of its maximum dimension to a wall. (Refer to Figure 3).

5. OPERATION

The Grate Nozzle is a deluge discharge device located at the floor level of an aircraft hangar. Grate Nozzles provide floor coverage by discharging foam solution at the floor level in a 25' radius 90° or 180° discharge pattern for the Models GN200/090 and GN200/180, respectively. Grate Nozzles are installed into a Model 1120 or Model 1126 trench drain grate. Grate Nozzles are supplied from a pressure regulating deluge or flow control system. Refer to appropriate Viking technical data pages.

6. INSPECTION, TESTING AND MAINTENANCE

Grate Nozzles are open discharge devices and require inspection, per NFPA 25, be conducted at least annually. As the nozzles are part of a deluge system, system testing and maintenance shall be that of NFPA 25 and the manufacturer's recommendations.

If Grate Nozzles are installed in an area subject to freezing, frequent inspections may be required to ensure particles of ice have not formed in front of the discharge ports of the Grate Nozzle.

7. AVAILABILITY AND SERVICE

Viking Grate Nozzles and Trench Drain Grates are available through a network of domestic and international distributors. See the Yellow Pages of the telephone directory for a local distributor (listed under "Sprinklers-Automatic-Fire") or contact Viking.

8. GUARANTEES

For details of warranty, refer to Viking's current list price schedule or contact The Viking Corporation directly.



TECHNICAL DATA

**90° AND 180°
GRATE NOZZLE®
MODEL GN200**

The Viking Corporation, 210 N Industrial Park Drive, Hastings MI 49058
 Telephone: 269-945-9501 Technical Services: 877-384-5464 Fax: 269-818-1680 Email: techsvcs@vikingcorp.com
 Visit the Viking website for the latest edition of this technical data page www.vikinggroupinc.com

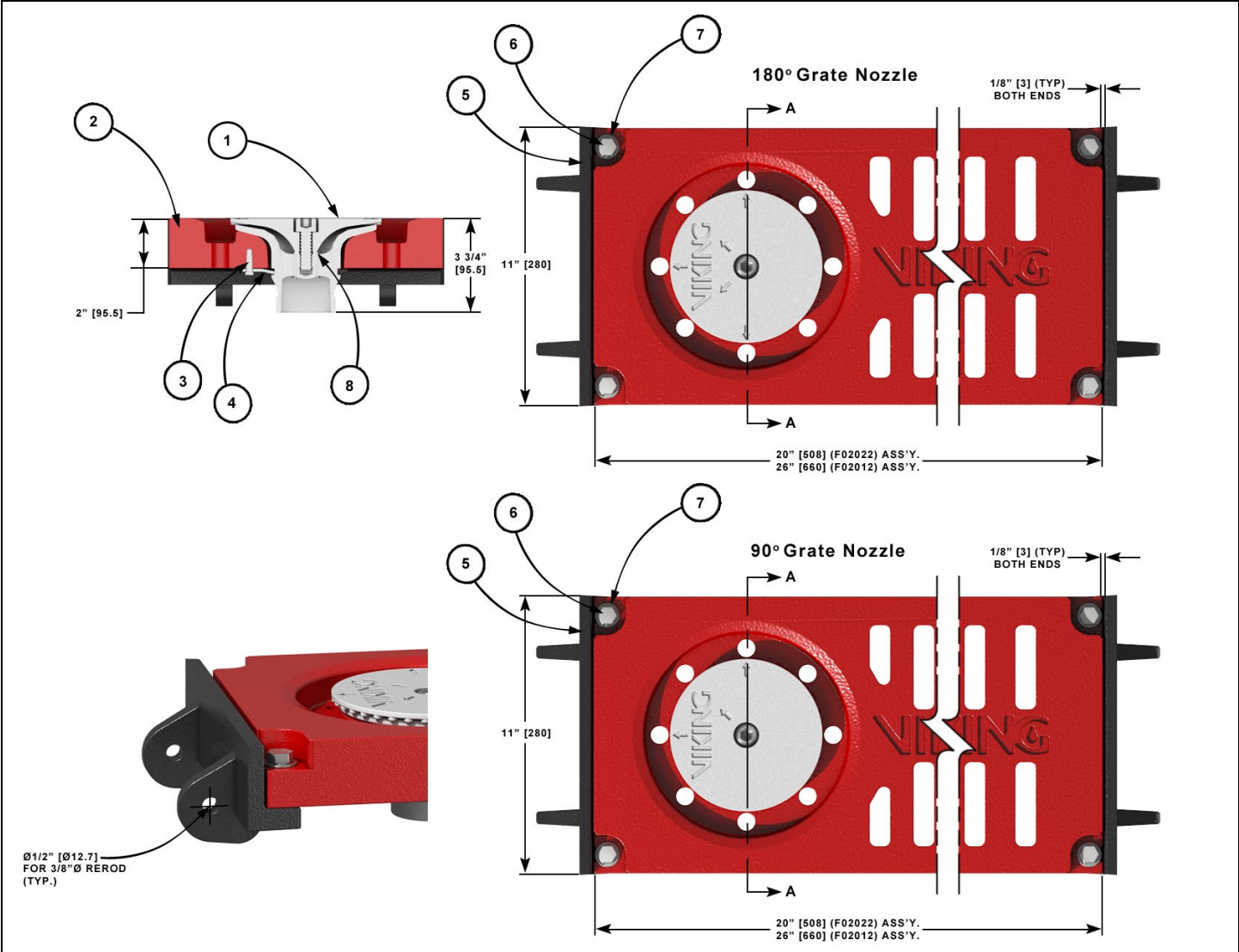

ITEM NO.	PART NUMBER				DESCRIPTION	MATERIAL	NO. REQ'D
	20" 90° F13687	26" 90° F13686	20" 180° F13690	26" 180° F13689			
1	F13684		F13685		Nozzle Assembly	316 Stainless Steel	1
2	F02020/Q08	F02003/Q08	F02020/Q08	F02003/Q08	Grate	80-55-06 Ductile Iron	1
3	01761A				Screw, H.H.C., 1/4-20 x 1/2" Lg.	18-8 Stainless Steel	3
4	F02008				Spring Clip	316 Stainless Steel	3
5	F02024Q/B				"X" Frame Support	Class 35B Cast Iron	2
6	10949				Screw, H.H.C., 3/8-16 x 1-1/2 Lg.	18-8 Stainless Steel	4
7	10951				3/8 Flat Washer	316 Stainless Steel	4
8	F02007				PTFE Washer	PTFE	1

Figure 1 - Replacement Parts



TECHNICAL DATA

90° AND 180°
GRATE NOZZLE®
MODEL GN200

The Viking Corporation, 210 N Industrial Park Drive, Hastings MI 49058
Telephone: 269-945-9501 Technical Services: 877-384-5464 Fax: 269-818-1680 Email: techsvcs@vikingcorp.com
Visit the Viking website for the latest edition of this technical data page www.vikinggroupinc.com

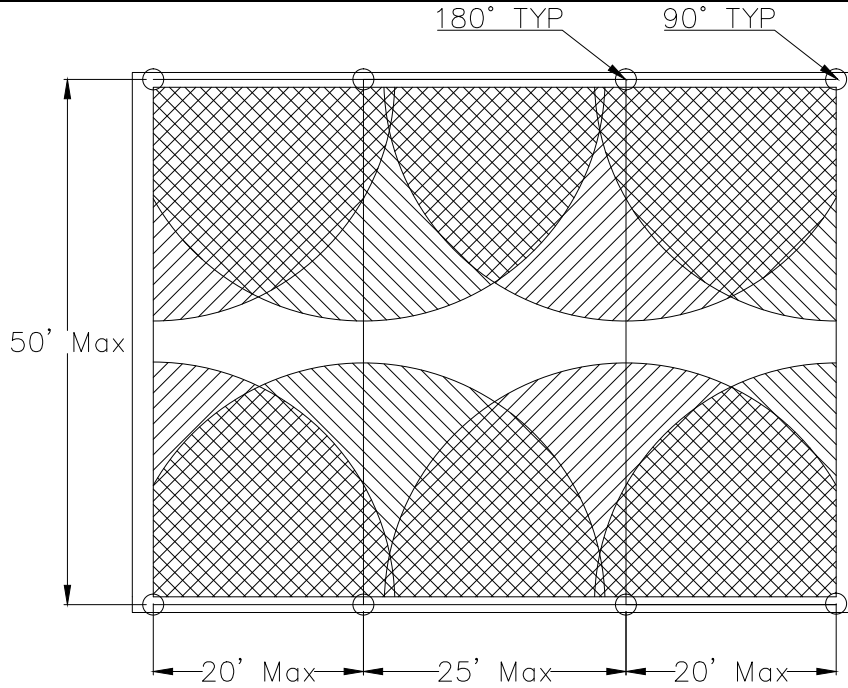

Figure 2a - Typical Nozzle and Trench Heliport using 90° Nozzles in Corners and 180° Nozzles in Centers

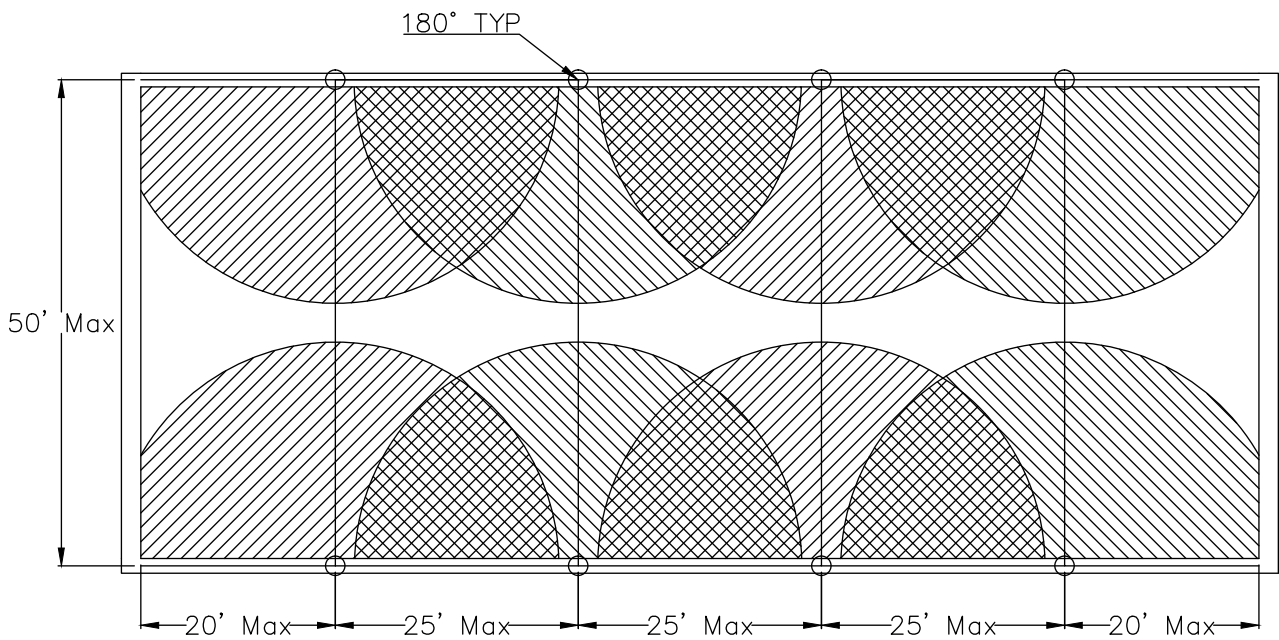

Figure 2b - Typical Nozzle and Trench Heliport using 180° Nozzles



TECHNICAL DATA

90° AND 180° GRATE NOZZLE® MODEL GN200

The Viking Corporation, 210 N Industrial Park Drive, Hastings MI 49058
Telephone: 269-945-9501 Technical Services: 877-384-5464 Fax: 269-818-1680 Email: techsvcs@vikingcorp.com
Visit the Viking website for the latest edition of this technical data page www.vikinggroupinc.com

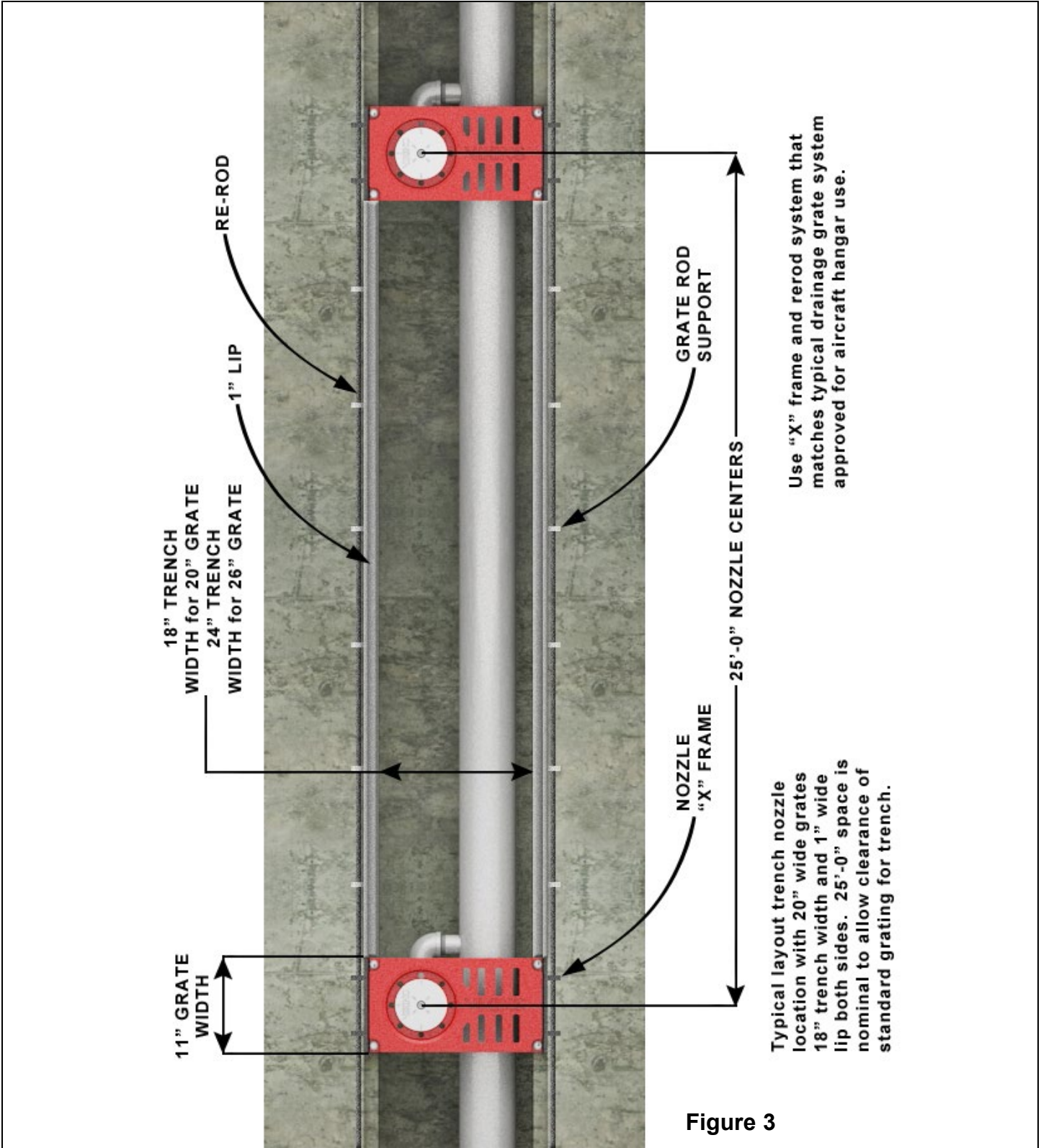

Figure 3



TECHNICAL DATA

90° AND 180°
GRATE NOZZLE®
MODEL GN200

The Viking Corporation, 210 N Industrial Park Drive, Hastings MI 49058
Telephone: 269-945-9501 Technical Services: 877-384-5464 Fax: 269-818-1680 Email: techsvcs@vikingcorp.com
Visit the Viking website for the latest edition of this technical data page www.vikinggroupinc.com

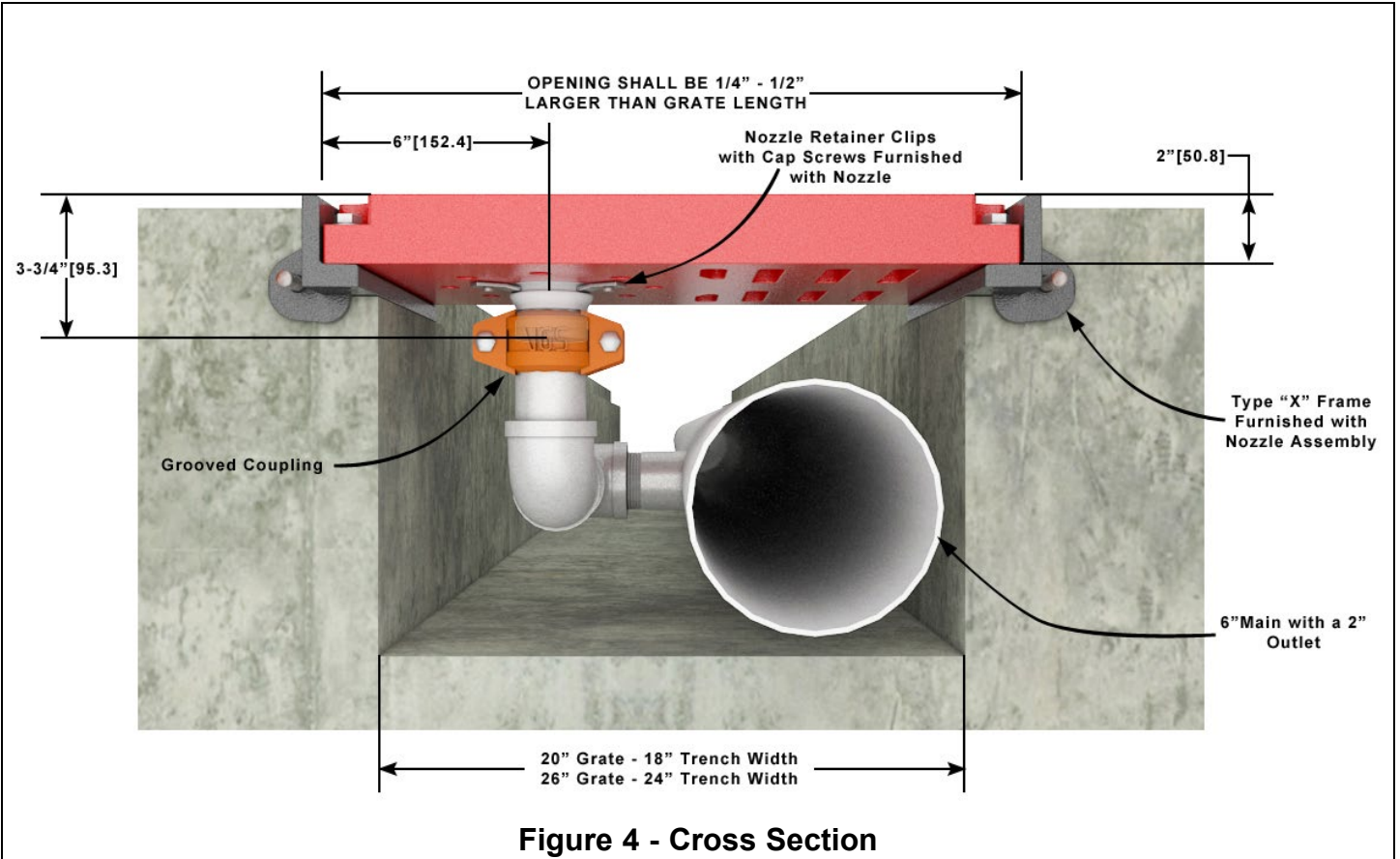

Figure 4 - Cross Section

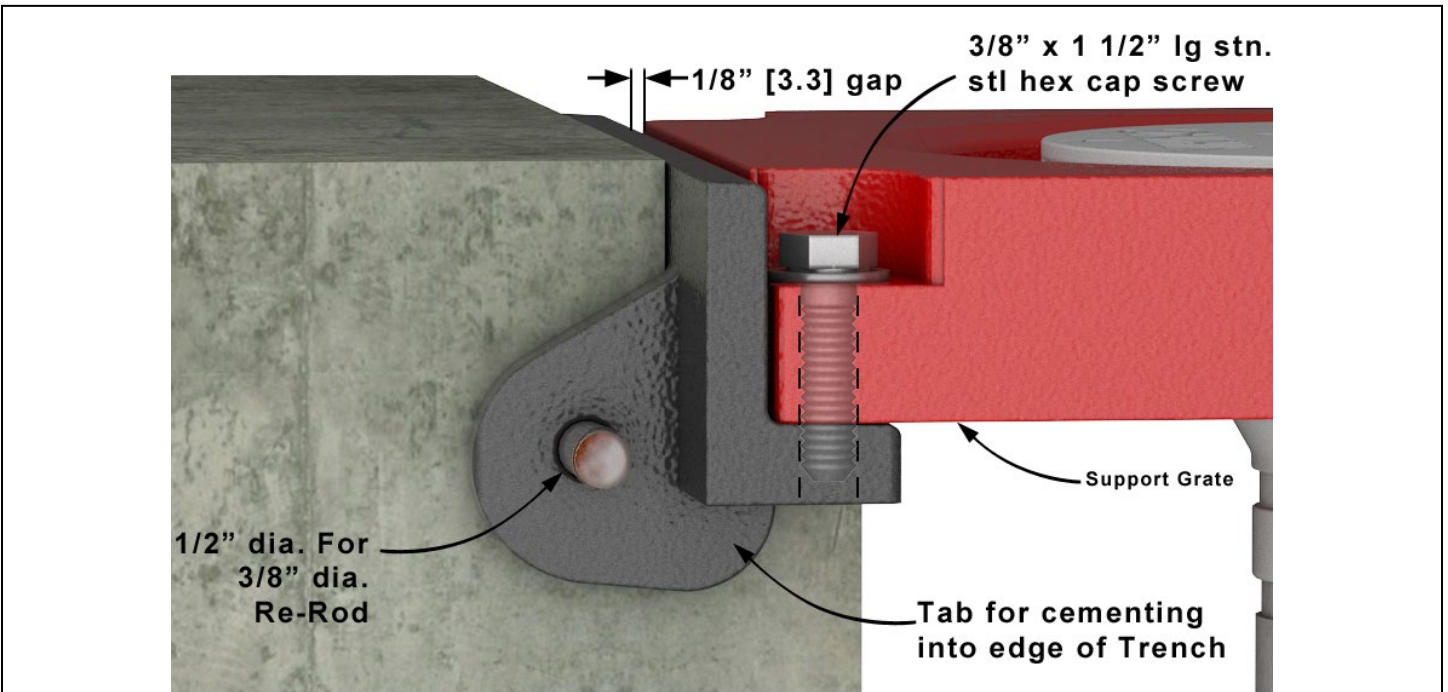

Figure 5 - X-Frame Detail



TECHNICAL DATA

90° AND 180°
GRATE NOZZLE®
MODEL GN200

The Viking Corporation, 210 N Industrial Park Drive, Hastings MI 49058
Telephone: 269-945-9501 Technical Services: 877-384-5464 Fax: 269-818-1680 Email: techsvcs@vikingcorp.com
Visit the Viking website for the latest edition of this technical data page www.vikinggroupinc.com

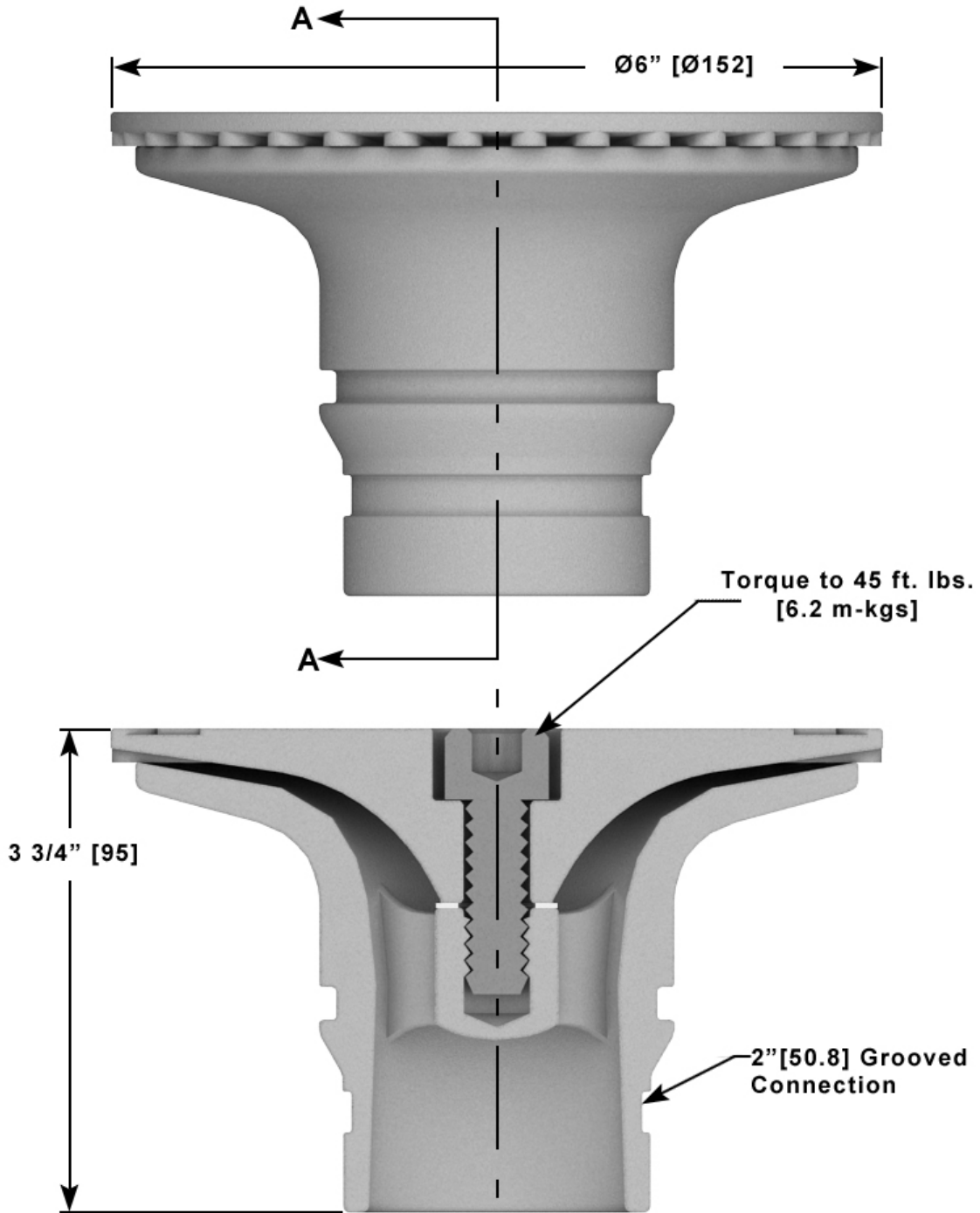

Section A-A
Figure 6